

USER MANUAL
N1

Version 23.02

SOFT

TABLE OF CONTENTS

Chapter		
1	Precautions	5
1.1	Overview	5
1.2	Limitation	5
1.3	Danger in Use	5
1.4	Laser	8
2	Preparation	12
2.1	Storage	12
2.2	Setup	12
2.3	Battery	14
2.4	Tribrach	15
2.5	Power On	16
2.6	Registration Code	17
3	Introduction	19
3.1	Instrument Components	19
3.2	Keys	20
3.3	Screen	20
3.4	Tool Bar(Quick Access)	21
3.5	Abbreviation	21
3.6	Star Key	22
3.7	Hot Keys	23
4	Menu	24
5	Job	25
5.1	Creating a New Job	25
5.2	Editing a Job	26
6	Measure	27
6.1	Measure	27
6.2	File	28
6.3	Point Stake Out	29
6.4	Graph	30
7	Station	31
7.1	Known Point	31
7.2	Multiple Orient	32
7.3	Height Transfer	34

7.4	Backsight Check	35
7.5	Resection	36
7.6	Point to Line	38
7.7	Free Station	39
7.8	Station Setup w/o CP	41
8	Collect	43
8.1	Point	43
8.2	Distance Offset	44
8.3	Plane Offset	46
8.4	Column Offset	47
8.5	REM	48
8.6	MLM	50
8.7	Line & Extend Point	51
8.8	Line & Extend Angle	52
8.9	Sag Measure	53
8.10	Traverse	57
8.11	Cable Height	66
8.12	Point Projection	67

9	Stake Out	70
9.1	Overview	70
9.2	Point	73
9.3	CAD Stake Out	75
9.4	Angle & Distance	80
9.5	Direction Line	81
9.6	Line	82
9.7	Reference Line	83
9.8	Arc	87
10	Data Management	91
10.1	Point Management	91
10.2	Code Management	95
10.3	Q-Code Management	96
10.4	Map Management	97
10.5	Import Data	98
10.6	Export & Copy Data	103
11	COGO	107
11.1	Reduction	108

11.2	Traverse Adjustment	110
11.3	Calc.XYZ	110
11.4	Inverse	112
11.5	Area & Girth	113
11.6	Included Angle	114
11.7	Distance Conversion	115
11.8	Angle Conversion	115
11.9	Average	116
11.10	Equidistant Point	116
11.11	Triangle Calculation	117
11.12	Calculator	118
12	Road	119
12.1	Road Design	119
12.2	Road Stake Out	126
13	Setting	129
14	Inspection & Adjustment	132
14.1	Plate Vial	132

14.2	Circular Vial	133
14.3	Tilt-Sensor	133
14.4	Reticle Unit	134
14.5	Sight of View & Horizontal Axis	135
14.6	Vertical& Horizontal Axis	136
14.7	Vertical Index	137
14.8	Vertical 0 (I-Angle)	137
14.9	Combined Adjustment	139
14.10	Instrument Constant K	139
14.11	Sight of View &Emitting Axis	140

Appendix A. Menu Tree	141
Appendix B. Data Format	142
Appendix C. Traverse Level	145

Copyright ©South Surveying & Mapping Technology CO.,LTD All Right Reserved

1. PRECAUTIONS

1.1 OVERVIEW

Congratulations on the purchase of SOUTH N1 Total Station!

The following safety instructions specify the responsibilities of the product owner and user.

The product owner must ensure that all users of the instrument know and follow these regulations or instructions.

1.2 LIMITATION

Environment	The environmental conditions of the instrument are similar to those that people can adapt to: it is not suitable for corrosive, flammable and explosive occasions.
--------------------	--

Danger	When working in dangerous areas, or any areas close to electric devices, the user must ask for local safety authority in advance.
---------------	---

1.3 DANGER IN USE

Caution	After the instrument is collided, re-assembled, stored for a long time and transported, please check and calibrate the equipment.
----------------	---

Prevention:

Check the instrument regularly according to the instructions in the user manual, especially before and after the important measurement tasks.

Danger

It is very dangerous to use prism pole near the electrical equipment such as electrified cables or electrified railways.

Prevention:

Keep a safe distance from power facilities. If you must work in this environment, please contact the safety department responsible for these electrical equipment and follow their instructions.

Caution

If the instrument is used to observe the sun directly, the eyes and optical system might be damaged because of the magnifying effect.

Prevention:

Don't aim the telescope directly at the sun without a sun filter.

Warning

In measurement, if users do not pay attention to the surrounding conditions, there will be a risk of accidents, such as obstacles, or traffic vehicles in the setting out process.

Prevention:

The product owner must ensure that all the users are aware of possible hazards.

Warning

If the survey site does not have enough safety facilities and signs, it may cause

dangerous situations.

Prevention:

Always ensure the safety of the work site. Always check the safety and accident prevention regulations and traffic rules.

Caution

If the accessories are not firmly connected to the instrument, it might be damaged.

Prevention:

When installing the instrument, ensure that the accessories are correctly, properly and safely fixed in place.

Warning

If the instrument is used with accessories, such as centering rod, the risk of lightning stroke will be increased.

Prevention:

Do not survey in the field under thunderstorm days.

Caution

During the transportation of battery, the improper mechanical influence may cause fire.

Prevention:

Discharge the battery before transportation.

During battery transportation, the product owner must comply with domestic and international regulations and guidelines.

Warning

Strong mechanical pressure, high temperature or falling into liquid may cause battery leakage, fire or explosion.

Prevention:

Protect the battery from mechanical impact and high temperature environment. Do not drop the battery or immerse the battery in liquid.

Warning

If the battery is short circuited, such as touching jewelry, keys, metal pieces or metal, the battery may be overheated and damaged or catch fire, such as when the battery is put in a pocket.

Prevention:

Make sure that the battery end is not in contact with metal objects

Warning

Only the distributor who authorized by South is qualified to repair the products.

1.4 LASER

Warning

The EDM rangefinder built in the total station will emit a visible red laser through the objective lens. which is identified by the following signs:

A warning label "LASER 3R" is attached above the vertical tangent screw, and the same label is attached on the opposite side.

This product belongs to Class 3R laser product, according to the standards

GB7247.1-2012: Safety of Laser Products.

Warning

From the perspective of safety, Class 3R laser products are potentially dangerous.

Prevention:

- 1) Avoid direct eye contact with the laser beam.
 - 2) Do not irradiate others with laser beam.
-

Warning

The potential safety is not only the direct viewing laser beam, but also the laser beam reflected by prism, window, mirror and metal surface.

Prevention:

- 1) Do not aim at objects that reflect strongly, such as mirrors, or objects that emit unnecessary reflected light.
 - 2) When the laser is turned on and in the laser aiming or distance measurement mode, do not look at the laser beam near to the target. The prism can only be aimed through the telescope of the total station.
-

Warning

It is dangerous to use Class 3R laser equipment incorrectly.

Prevention:

The user should take effective safety precautions and control the possible danger within the distance (according to GB7247.1-2012).

Class 3R

Class 3R laser products are used outdoors and on construction sites (surveying, alignment, leveling)

A. Only trained and certified personnel can install, commission and operate the laser equipment.

B. Set up laser warning signs within the operation area.

C. Prevent directly looking at the laser beam with eyes or using optical instruments to watch the laser beam.

D. In order to prevent the damage, the laser beam shall be blocked at the end of the working route. When the laser beam passes through the restricted area (in harmful distance*) or when someone is moving in this area, the laser must be stopped.

E. The path of the laser beam must be set above or below the line of sight of people.

F. When the laser product is not in use, it shall be properly kept and stored.

G. Prevent the laser beam reflected from the mirror, metal, window, etc.

*Harmful distance refers to the maximum distance from the starting point of the laser beam to the point where the laser beam weakens without harm.

A built-in rangefinder product equipped with a Class 3R laser has a harmful distance of 1000m (3300ft). Beyond this distance, the laser intensity will be reduced to Class 1 (It won't be harmful directly to the eyes).

Description	Laser Plummet	EDM
Wavelength	635nm	635nm
Max. Radiant Power	3.5mW	6.5mW
Divergence Angle	1mrad	0.4mrad

2. PREPARATION

2.1 STORAGE

Unpacking

Lay down the case lightly with the cover upward.
Unlock the case, and take out the instrument.

Storage of Instrument

Cover the cap, put the instrument into the case with the vertical clamp screw and circular bubble to the upwards (lens towards tribrach).

2.2 SETUP

Setting up the tripod

- A. Loosen the screws on the tripod legs, pull out to the required length and tighten the screws.
- B. Make the center of tripod and the occupied point approximately on the same plumb line.
- C. Step on the tripod to make sure if it is well stationed on the ground.

Instrument setup (with Laser Plummet)

- A. Place and lock the instrument carefully on the tripod
- B. Turn on the instrument and activate the laser plummet. Hold the two legs which are not fixed on the ground and decide the position to fix according to the laser dot. When the laser dot is roughly on the station point, fix those 2 legs.

C. Leveling the instrument by circular vial.

- a) Rotate the foot-screw A and B to move the bubble in the circular vial, in which case the bubble is located on a line perpendicular to a line running through the centers of the two leveling screw being adjusted .
- b) Rotate the foot-screw C to move the bubble to the center of the circular vial.

D. Precisely leveling by plate vial

- 1) Rotate the instrument horizontally by If the laser dot doesn't stay at the center position, please slightly loosen the screw under the tripod head and move the instrument (don't rotate the instrument) until the laser dot is

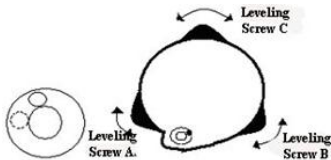

loosening the horizontal clamp unit and place the plate vial parallel to the line connecting rotating the foot-screw A and B, and then bring the bubble to the center of the plate vial by rotating the foot-screw A and B.

- 2) Rotate the instrument in 90° (100gon) around its vertical axis and turn the remaining leveling screw or leveling C to center the bubble once more.

- 3) Repeat the steps and check whether the bubble is correctly centered in all directions on the station point. Tighten the screw and level the instrument again. Repeat these steps until the instrument is precisely centered and leveled.

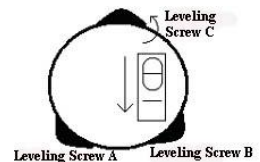
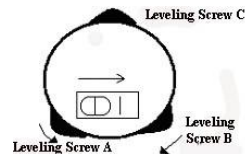

Electronic Bubble

To ensure a precise angle measurement, you can also level the instrument by E-bubble.

[Tilt-X]: Tilt compensation in X-direction

[Tilt-XY]: Tilt compensation in XY-direction.

[Tilt-Off]: Turn off the tilt sensor.

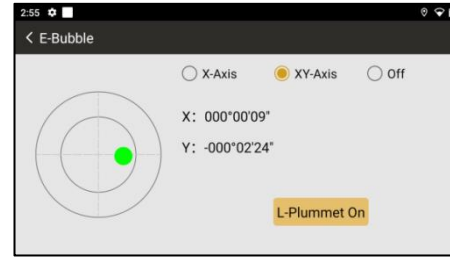

2.3 BATTERY

Initial Use/Charging

The battery should be charged only by the official charger NC-10. The battery must be charged before the first time operation.

Indicator: Red - Charging;

Green - Completed;

Green Flashes - Error

Input: 70V-240V 50/60Hz;

Output: 7.4V-1.2A)

The allowable charging temperature range is 0 °C to +40 °C . For optimum charging, we recommend charging the battery at +10 °C to+20 °C.

It is normal for the battery to become hot during charging. If the temperature is too high, the charger will not work.

For new batteries or batteries that have not been used for a long time (over three months), it will be more effective to have a complete

charge and discharge before the work.

Remained Capacity

When the remaining voltage is less than one grid, please stop your operation and charge it as soon as possible.

Working time depends on the environmental conditions, such as ambient temperature,

charging times. For safety reasons, please charge in advance or prepare some backup batteries.

The remaining capacity is related to the current measurement mode. In angle measurement mode, the capacity is sufficient, which cannot ensure that the battery can also be used in distance measurement mode.

2.4 TRIBRACH

Dismounting

Turn the locking knob in 180° counter-clockwise to disengage anchor jaws, and take off the instrument.

Mounting

Insert three anchor jaws into holes of tribrach and line up the directing stub. Turn the locking knob about 180° clockwise to mounting the instrument.

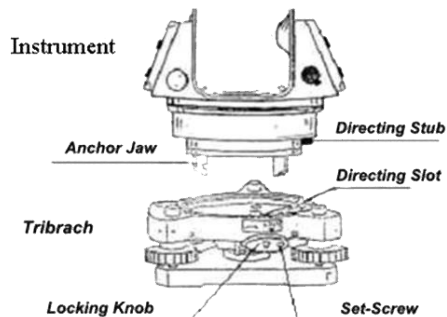

2.5 POWER ON

Power On

Press and hold the power key in 2 seconds until the screen lights up.

Power Off

Press and hold the power key in 1 seconds until the shut down menu pops up. Please keep the normal shut down steps to avoid the data lost.

2.6 REGISTRATION CODE

2.6.1 Check the Status in TServer.

Description Before working, the user should check whether the device connection in the TServer App is correct and whether the registration time has expired or not.

Access Select **[TServer]** : **[Connect]** or **[Disconnect]**; **[Settings]**\ **[Register]**

Registration

Status

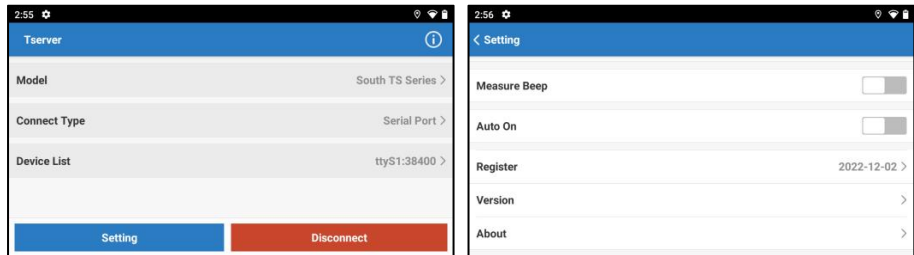

- **Do not change any settings in TServer without authorization.**
- If the instrument is blocked, please reconnect the TServer.
- If the angle value is not displayed, or the value does not change when the instrument is rotated, the registration code might be expired.
- If the laser pointer or plummet can not be activated, the problem might be caused by register code, too.

2.6.2 Registration Code

Description

Registration code for Survey Star onboard.

Access

There are two methods to register your total station:

1) Auto: Connect 4G/WIFI network, select **[TServer]** for auto registration.

If it does not work, the codes can be registered by manual.

2) Manual: Select **[TServer]\[Setting]\[Register]\Input code in 36 digits\[/b>**[Register]****

Registration

Code

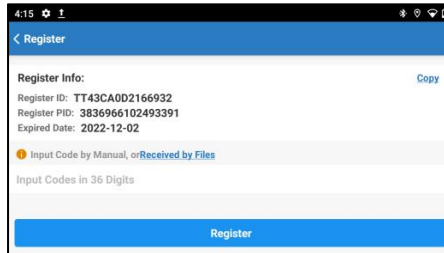

3. INTRODUCTION

3.1 INSTRUMENT COMPONENTS

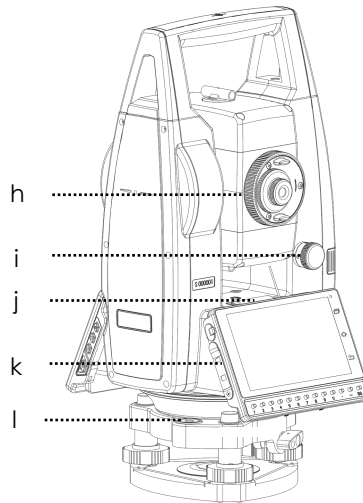
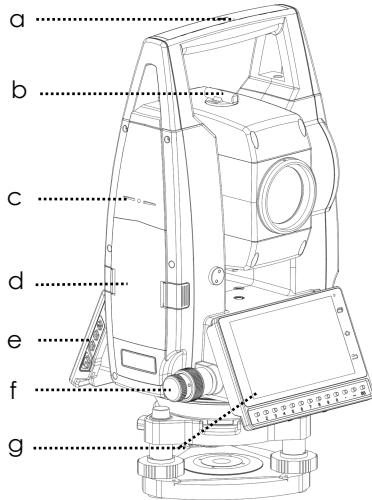

- a) Handle
- b) Collimator
- c) Central Mark
- d) Battery
- e) Keys
- f) Horizontal Tangent Screw
- g) Display Unit with Keys
- h) Eyepiece Unit
- i) Vertical Tangent Screw
- j) Plate Vial
- k) Card Slot
- l) Circular Vial

3.2 KEYS

Key	Description
1-9 / . / -	Numeric keys, which can be defined by user.
BS	Backspace
⏻	Power on or off
↑ ↓	Move the cursor right or left.

Key	Description
Fn	Function key, which can be defined by user.
☐	Sub-menu
🏠	Back to home page
↶	Back to last page



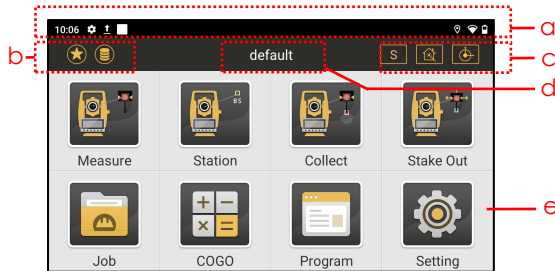

3.3 SCREEN



The screen is separate into four parts:

- Status bar (e.g. time, setting, download, location, WIFI connection, battery.)
- Quick access
- Measure mode (e.g. mode, target, tilt sensor)
- Current job
- Main menu

3.4 TOOL BAR (QUICK ACCESS)

Icons	Description
	Quick access to star key.
	Quick access to data manage.
	Quick access to measure mode (Single/N Times/Continuous/ Tracking)
	Quick access to targets. (Non-p/ Reflective Sheet/ Prism)
	Tilt sensor (XY-Axis/X-Axis/Off)

3.5 ABBREVIATION

Icon	Description
V/VA	Vertical angle
V%	Vertical angle (%)
HL/HR	Horizontal left/ right
SD	Slope distance
HD	Horizontal distance
VD	Vertical distance
N/E/Z	North/ East/ Zenith

Icon	Description
Pt.N	Point number
CP	Control point
STN	Station
BS	Backsight
R.Ht	Reflector height
Ins.Ht	Instrument height

3.6 STAR KEY

Description The star keys provide a quick access to the settings and the functions of total station.

Access 1) Select **[Survey Star]: [★]**
2) Slide the left edge of the screen to the right

Star Keys

Key	Description
1.Laser Pointer	Open the laser pointer.
2.Reticle Backlight	Open the reticle (crosshair) backlight in telescope.
3.Laser Plummet	Open the laser plummet.
4.Temp.&Pressure	Set temperature, pressure, PPM. 20 °C /1013hPa in default.
5.Prism Constant	Set prism constant, -30.0mm in default.

3.7 HOT KEYS

Description

Hot keys provide a shortcut to user-defined functions or applications assigned to the keys.

Access

Select **[Survey Star]: [Setting] \ [Function Key]** \ Select the keys

Hot Keys

Key	Description
Measure Button	Measure / all (measure + save)
Fn	Undefined / laser pointer / reticle / laser plummet / soft-keypad
[0]-[9], [.] , [-]	Undefined / laser pointer / reticle / laser plummet / known point / free station / point / point stake out.

4. MAIN MENU

Main Menu

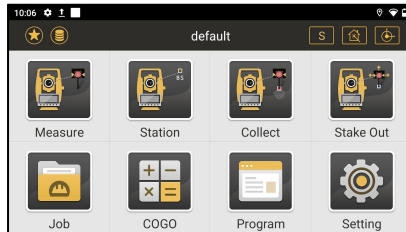

Description

Main Menu	Description
Measure	To simply survey, select and stake out a point with graphics.
Station	To setup the station before works.
Collect	To collect a point, as well as select and start an application.
Stake Out	To stake out a point.
Job	To manage job.
COGO	To start a coordinated geometry application.
Program	To design and stake out a road.
Setting	To make settings regarding the software and the display unit

5. JOB

5.1 CREATING A NEW JOB

Access

Select Main Menu:[Job]\[+]\

Enter the job name, operator, time\[Done]

Create a new job



Keys	Descriptions
Job	A unique name for a new job.
Time	Display only. Time and date.
Operator	Editable field. Operator's name.
Note	Editable field. The software version is filled.

5.2 EDITING A JOB

Access Select Main Menu:[Job]\Select a job.
[Open], [Delete] or [View]

Edit a new job

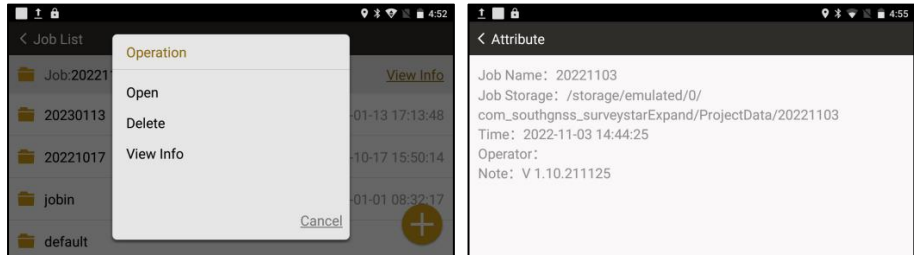

Keys	Descriptions
[Open]	Open the selected job.
[Delete]	Delete the selected job.
[View Info]	Check the job properties. Includes job name, storage location, time, operator and note.

6. MEASURE

6.1 MEASURE

Description

[Measure] is used for point measurement.

Access

Select Main Menu: [Measure] \ {Meas.} Page \ [Meas.] \ [Save]

{Measure}

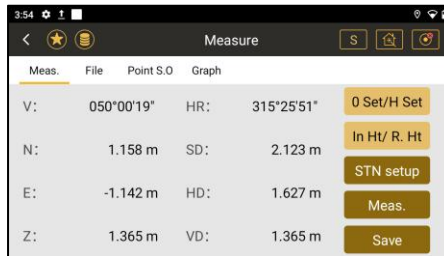

Key	Description
0 Set/ H Set	Set the current horizontal angle to 0 or a certain value.
In Ht/ R. Ht	Set the instrument height and reflector height.
STN Setup	Setup the station by two known points.
Meas.	Measure
Save	Save the data with point name and code.

6.2 FILE

Description

Select the point from the other files.

Access

Select Main Menu: **[Measure]**\{File} Page

{File}

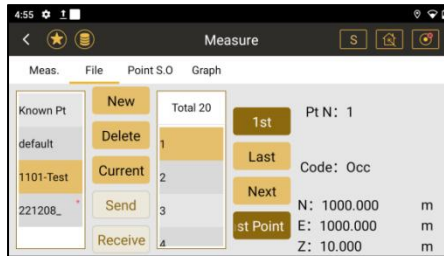

Keys	Description
New	Create a new job.
Delete	Delete the selected job.
Current	Set the selected job as current job.
Send	Send data via MSMT.

Keys	Description
1st	First point.
Last	Last point.
Next	Next point.
Last Pt	Last point in the job.
Receive	Receive data via MSMT.

6.3 POINT STAKE-OUT

Description

Stake out points by coordinate, please refers to Chapter 9.2

Access

Select Main Menu: **[Measure]**\{Point S.O} Page

{Point S.O}

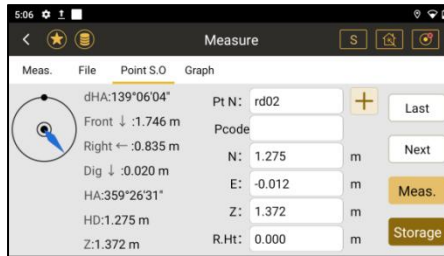

Display	Description
E-Compass	Direction of the target
dHA	HA difference
Front/Back	Move to the front/back
Left/Right	Move to the left/right
Fill/Dig	Move to the up/down

Keys	Description
+	Add point
Last	Last point
Next	Next point
Meas.	Measure the prism
Storage	Save the point

6.4 GRAPH

Description

Graph is an interactive display feature embedded in Survey Star. It offers a graphical display of the survey elements with base map, which allows a better understanding of the measurement. Normally it will be loaded automatically.



Access

Select Main Menu: **{Measure}\{Graph}** page.

Use two fingers on the screen to zoom in or zoom out.

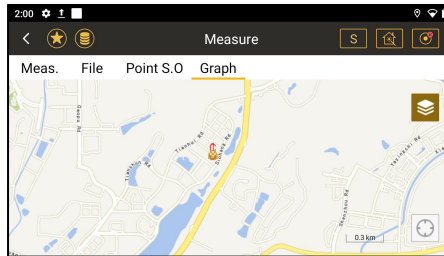
{Graph}



Keys	Description
	Change the layers screen. It is possible to make layers from the CAD file visible or invisible in map.
	Click to locate the current station to the center of screen.

7. STATION

7.1 KNOWN PT

Description

The coordinates of station point are required for setup. The instrument can be oriented by a known point, or an unknown point with assumed azimuth.

Access

1) Select Main Menu: **[Station]\[Known Pt]**. Press **[+]** to select a station.

Step-by-step

2) Select orientation method: by known backsight point or by assumed azimuth.

3) Input instrument height and reflector height. Aim at the target, press **[Setting]**.

Known Point

10:43 Known Pt

STN: 2 HR: 188°29'59"

BS Pt Azimuth 190°51'00"

Ins.Ht: 0.000 m Aim at the BS!

R.Ht: 0.000 m Multiple Orient

Keys	Description
BS Pt	Select a known backsight point.
Azimuth	Select an assumed azimuth for orientation.

7.2 MULTIPLE ORIENT

Description

The instrument can be oriented by more than one backsight points.

Note: A maximum of 10 points can be measured and used for the calculation. This program is similar to Resection (Chapter 7.5), the difference is whether the coordinates of station is known or not. In multiple orientation, it's known.

Access

Step-by-step

- 1) Select Main Menu:[Station]\[Known Pt]. Add a station point.
- 2) Click [Multiple Orient]\[Setting] to enter the point list for multiple orient.
- 3) Press [Meas.1st Pt]\[+]\[Angle] or [Ang.& Dist] to measure the backsight.
- 4) Press [Done] to save it in point list. Repeat the steps for the others.
- 5) Press [COGO]\[Set] to see the calculated station.

Multiple Orient

Meas. No.	Data Item	Graph	N	E
1	BBS1		23.115	113.192
2	BBS2		23.050	113.799
3	BBS3		23.005	114.397
4	BBS4		22.455	113.746

Meas. 6 Pt COGO

Pt N: + HR: 349°38'57" Angle

Ins.Ht: 0.000 m VA: 053°38'32" Ang.&Dist.

R.Ht 0.000 m SD: m Done

Keys	Description
Meas.1 Pt	Measure the known points one by one (max.10 points).
COGO	Calculate the coordinate of station after measurements.
Angle	Measure angles only.
Ang. & Dist.	Measure angles and distances.
Done	Confirm the measurement.

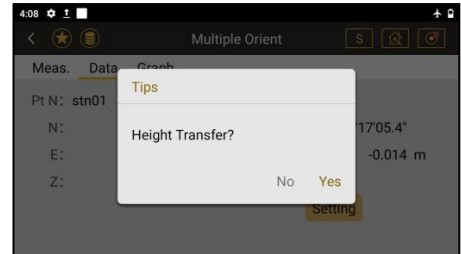
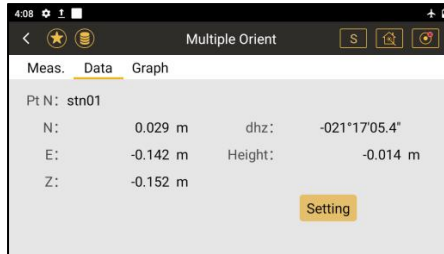

Keys	Description
N/E/Z	Coordinates of station.
dHz	Difference of horizontal angle.
Height	Height of station.

Next Step

Height Transfer (Refers to Chapter 7.3) if necessary.

7.3 HEIGHT TRANSFER

Description Calculate the station height by measuring a point with known height. Only the height of station will be updated.

Access 1) Select Main Menu:[Station]\[STN.Ht].

Step-by-step 2) Press **[+]**, input or select the height of known points, Ins.Ht, R.Ht.

3) Press **[Meas.]** and **[Setting]** to measure and update the height of station.

Height Transfer

The screenshot shows the 'STN.Ht' menu with the following data:

Height:	1.378	m	Call
Ins.Ht:	1.500	m	R.Ht: 1.000 m
VD:	1.353	m	
Calcu.Ht:	-0.475	m	Meas.
STN.Ht:	0.004	m	Setting

Display	Description
VD	Vertical distance between the station and known point.
Calcu.H	Calculated height of station.
STN.Ht	Updated height of station.

7.4 BACKSIGHT CHECK

Description

Check the residual of backsight after station setup.

Access

1) Select Main Menu:[Station]\[BS Check].

Step-by-step

2) Aim at the backsight, press **[Meas.]** to see the coordinate and difference.

3) Press **[Reset]** to set the current point as backsight.

Backsight Check

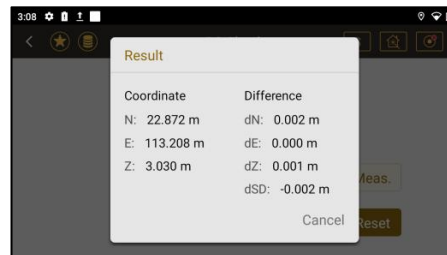
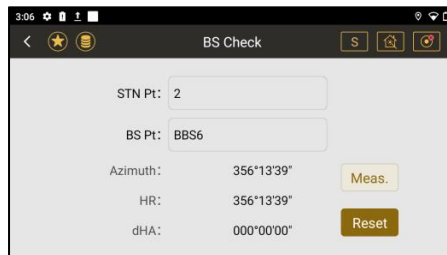

Display	Description
Azimuth	Azimuth of backsight
HR/HL	HA of measured point
dHA	Difference of HA

Display	Description
N/E/Z	Coordinate of target
dN/dE/dZ	Difference of coordinate
dSD	Difference of SD

7.5 RESECTION

Description

Resection is used to determine the instrument position from measurements of at least two known points (maximum 7 points). Only angles or both angles and distances can be measured.

The calculation requires at least three angle data or two distance data.

Access

1) Select Main Menu: **[Station]\[Resection]**

Step-by-step

2) Press **[Meas No.1 Pt]\[Angle][Ang.&Dist]\[Done]** to measure the known points

3) Press **[COGO]\[STN Setup]\[Stn Set]** to calculate and set the station.

Resection

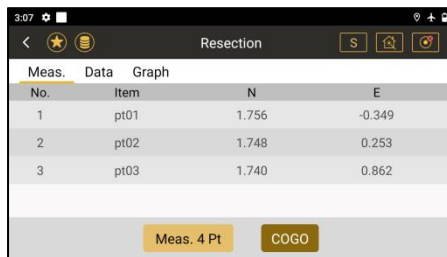

Meas. No.	Data Item	Graph	N	E
1	pt01		1.756	-0.349
2	pt02		1.748	0.253
3	pt03		1.740	0.862

Buttons: Meas. 4 Pt, COGO

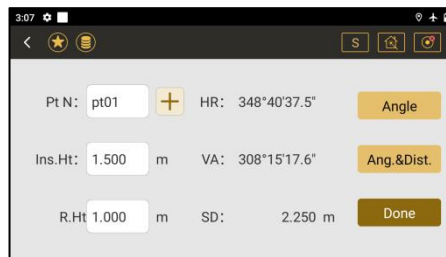

Pt N: pt01 + HR: 348°40'37.5" Angle

Ins.Ht: 1.500 m VA: 308°15'17.6" Ang.&Dist.

R.Ht 1.000 m SD: 2.250 m Done

Display	Description
Meas.1 Pt	Measure the known points one by one (max. 7 points).

COGO	Calculate the coordinate of station after measurements.
Angle	Measure angles only.
Ang. & Dist.	Measure angles and distances.
Done	Confirm the measurement.

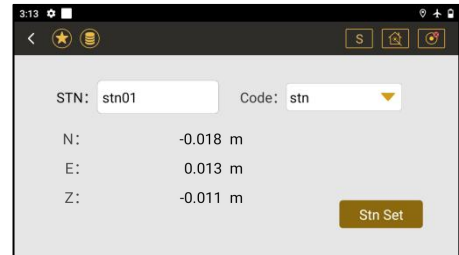
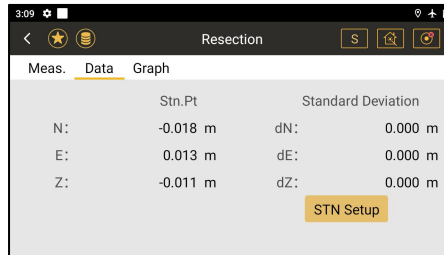

Display	Description
N/E/Z	Calculated coordinates.
dN/dE/dZ	The difference between given and calculated coordinates.

Note: If the angles between the known points are too small or too large, the accuracy will be effected. The station height is calculated by the distance. If only angles are measured, the height will be determined by the angle of known points.

7.6 POINT TO LINE

Description

Point to Line can be used to calculate the local coordinates for the station. The result is calculated from distance and angle measurements of two target points (A and B). Point A will be defined as the origin point, while point B will be defined as North direction.

Access

1) Select Main Menu: **[Station] \ [Point to Line]**.

Step-by-step

2) Press **[Meas.] \ [Meas.]** to measure point A and point B.

3) Press **[Next] \ [Next] \ [Stn Set]** to calculate and set the station.

Point To Line

The image displays two screenshots of the 'Point to Line' measurement interface. The left screenshot shows the input stage with fields for 'Ins.Ht' (1.500 m) and 'R.Ht' (1.000 m). Below these are calculated values for 'A-HD' (2.210 m) and 'B-HD' (2.144 m), each with a 'Meas.' button. A 'Next' button is also present. The right screenshot shows the results stage with 'A-B' at the top, followed by 'dHD' (2.061 m), 'dVD' (0.040 m), and 'dSD' (2.061 m), with a 'Next' button at the bottom right.

Display	Description
A-HD	HD from station to 1 st point
B-HD	HD from station to 2 nd point
dHD	Difference of HD for A-B

Display	Description
dVD	Difference of VD for A-B
dSD	Difference of SD for A-B
N/E/Z	Coordinates of station

7.7 FREE STATION

Description

In Free Station, the coordinate system will be settled by its local coordinate system.

Normally, the workflow is:

Station setup - Backsight oriented - Data collect.

With Free Station, it is:

Station setup - Data collect - Reduction with backsight.

After reduction, the local coordinates will convert to the real coordinates.

Access

- 1) Select Main Menu: **[Station]\[Free Station]**.
- 2) Press **[+]\[Setting]**.

Free Station

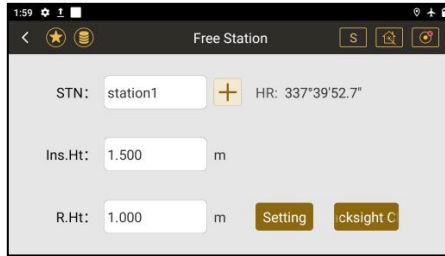

Display	Description
STN	Select or type a point as station
HR	Horizontal angle for current direction. It will be settled as 0.
Ins. Ht	Instrument height
R.Ht	Reflector height
[Backsight Checking]	Define the backsight direction. It can be set before or after the station setup.

Next Step

Data Collect. Refers to Chapter 8.1.

Reduction for Free Station. Refers to Chapter 11.1.1

7.8 STATION SETUP WITHOUT CONTROL POINT

Description

This function is used to setup the station when you don't have any control points.

All those local coordinates, which are measured under two different stations (A & B), can be converted to correct coordinates if there is a public point C exists.

Workflow:

Set station at A - Data collect (including a public point C) - Move station at B - Data collect (including a public point C) - Reduction

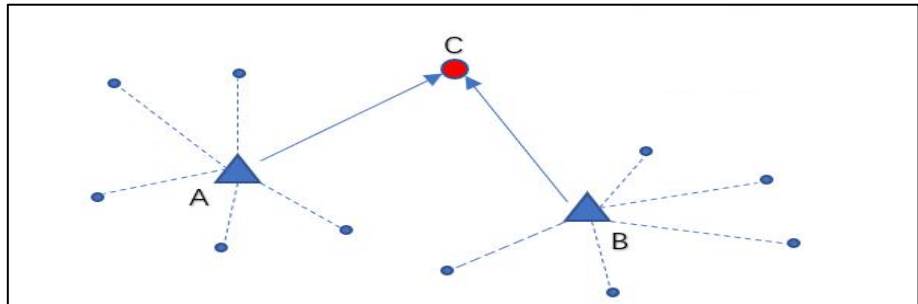

Access

Select Main Menu:[Station]\[STN Setup without CP]\[+]\[Setting]

Station Setup
without Control
Point

2:19

STN setup without CP

STN: A + HR: 000°00'02.6"

Ins.Ht: 1.500 m

R.Ht: 1.000 m Setting

Display	Description
STN	Select or type a point as station
HR	Horizontal angle for current direction. It will be settled as 0.
Ins. Ht	Instrument height
R.Ht	Reflector height

Next Step

Data Collect. Refers to Chapter 8.1

Reduction for Station Setup without CP. Refers to Chapter 11.1.2

8. COLLECT

8.1 POINT

Description

Measure and save the points.

Access

Select Main Menu: **[Collect]**\ **[Point]** \ **[Meas.]** or **[All]**

Collect Points

Display	Description
Pt N	Point name.
Code	Code. Press [+] \Qcode [+] to select the code. The position and links is marked for Southmap, it will not display on the map of total station.
R.Ht	Reflector height.

HR/HL	Horizontal left or right
V	Vertical angle
N/E/Z	North, east and zenith coordinates
HD/VD/SD	Horizontal / Vertical / Slope Distance
[Meas.]	Measure the target.
[Save]	Save the data.
[All]	Measure and save the coordinates in once.

8.2 DISTANCE OFFSET

Description

The distance offset calculates from measurement or coordinates with longitudinal, parallel offset and height differences of the target point relative to the known point.

Note: All directions are correspondent to the visual side of operator.

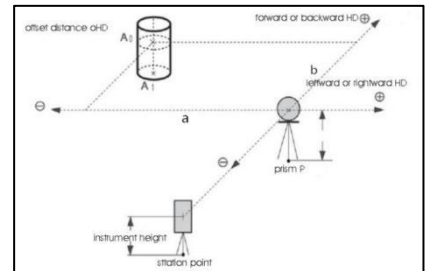

Access

- 1) Select Main Menu: **[Collect]**\ **[Dist.Offset]**.
- 2) Input lateral, longitudinal and altitude offset.
- 3) Press **[Dist]** or **[All]** to measure and calculate the offset coordinates.

Distance Offset

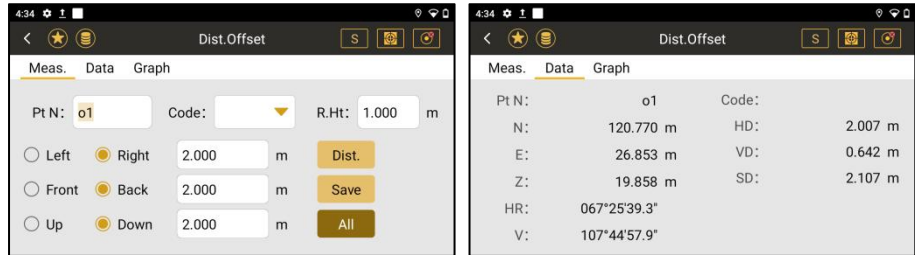

Display	Description
Pt N	Input the ID of offset point.
Left/Right	Input lateral deviation, from offset point to prism.
Front/Back	Input longitudinal deviation, from offset point to prism.
Up/Down	Input altitude deviation, from offset point to prism.
[Dist]	Measure the target.
[Save]	Save the data.
[All]	Measure and save the coordinates of offset point.

8.3 PLANE OFFSET

Description

This function calculates the points which cannot be measured directly.

Access

- 1) Select Main Menu: **[Collect] \ [Plane Offset]**.
- 2) Press **[Meas.]** to measure three points in a same plane
- 3) Rotate the telescope, aim at the unreachable point in this plane.
- 4) press **[Save]** to save the coordinate.

Plane Offset

Display	Description
[Meas.]	Measure three points in a same plane to define a plane.
[View]	Check the coordinate of measured point.
[Save]	Save the coordinate of calculated point.

Unmeas.	Display only. When the measurement is not completed.
Done	Display only. When the measurement is completed.

8.4 COLUMN OFFSET

Description

Column offset is widely used in measuring a hidden point that is not directly visible, for example the center of column as picture shown.

Measure the left and right edge (P2&P3) of column. Then measure the center point P1 in surface.

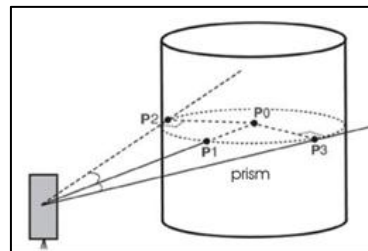

Access

1) Select Main Menu: **[Collect]\[Column Offset]**.

Step-by-step

2) Press **[Angle]\[Angle]\[Meas.]** to measure the edges and surface center.

3) Press **[Data]\[Save]** to check and save the coordinates of P0.

Column Offset

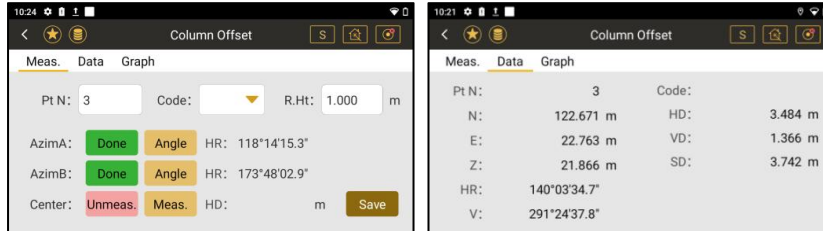

Keys	Description
[Angle]	Measure the angle of left and right edge.
[Meas.]	Measure the distance of surface center.
Unmeas.	Display only. When the measurement is not completed.
Done	Display only. When the measurement is completed.
[Save]	Save the coordinates.

8.5 REM

Description

When the target is hard to reach or hang in the air, for example, the electric cables, REM (Remote Height) can help you measure the point.

Access

1) Select Main Menu: **[Collect]\[REM]**.

- 2) Set a prism vertically under the target.
- 3) Input reflector height, press **[Ang.&Dist]** to measure the prism.
- 4) Rotate the telescope to the target.

REM

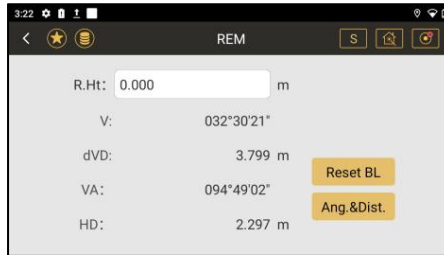

Display	Description
V	Vertical angle of target
dVD	Vertical distance of prism or the target
VA	Vertical angle of prism
HD	Horizontal distance of prism
[Ang&Dist]	Measuring the prism which is vertically under the target
[Reset BL]	When R.HT is unknown, aim at the pinpoint, press [Reset BL] to set the vertical distance to 0. Then rotate the telescope to target.

8.6 MLM

Description

MLM, is mainly used to compute the HD/VD/ SD/azimuth between two points.

- 1) MLM Radial(A-B, A-C) , lock the start point
- 2) MLM Cont. (A-B, B-C) , unlock the start point.

Access

- 1) Select Main Menu: **[Collect]\[MLM]**.
- 2) Press **[Meas]\[Ang.&Dist]\[Save]**.
- 3) Select calculation mode, lock or unlock the start point. Press **[COGO]**

MLM

Meas.	Data	Graph	
No.	Item	N	E
P1	A	2564800.839	440308.701
P2	B	2564801.384	440306.333
P3	C	2564791.013	440305.732

Lock Meas. COGO

HR: 102°58'18" Pt N: A

V: 028°06'36"

SD: 1.526 m R.Ht: 0.000 m

N: 2564800.839 m

E: 440308.701 m

Z: 22.846 m

Ang.&Dist. OK Save

Keys	Description
[Meas.]	Measure points.
[COGO]	Calculate the result base on points in data list.

[Lock]	Lock (A-B, A-C, A-D, etc.) or unlock (A-B, B-C, C-D) mode.
[Ang & Dist]	Measure the angle, distance and coordinate.
[Save]	Save the measured point in data list.

8.7 LINE & EXTEND POINT

Description

It calculate the coordinates of an unknown point from a line defined by two points (P1, P2) with an inputted distance (calculated from P2).

Access

- 1) Select Main Menu: **[Collect]\[Line & Extend Point]**.
- 2) Enter the reflector height, press **[Meas]** to measure P1 and P2 as a baseline.
- 3) Press **[Dist.Set]** to enter the extend distance. Press **[Save]**.

Line&Extend Point

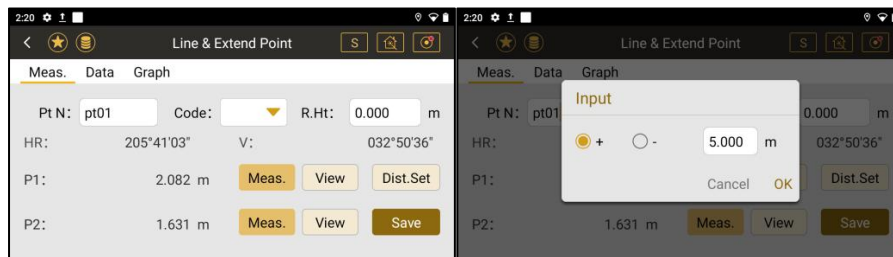

Keys	Description
[Meas.]	Measure points (P1, P2).
[View]	Check the coordinates for P1 and P2.
[Dist Set]	Set the extend distance which is based on P2.
[+]	Extend direction from P1-P2.
[-]	Extend direction from P2-P1.
[Save]	Calculate and save the coordinates of extend point.

8.8 LINE & EXTEND ANGLE

Description It calculate the coordinates of an unknown point from a line defined by two points (P1, P2) with an azimuth (calculated from P2).

Access

- 1) Select Main Menu: **[Collect]\[Line & Extend Angle]**.
- 2) Press **[Meas]** to measure P1 & P2 as a base line.
- 3) Press **[Meas]\[Save]** to measure and save the coordinates of extend point.

Line&Extend Angle

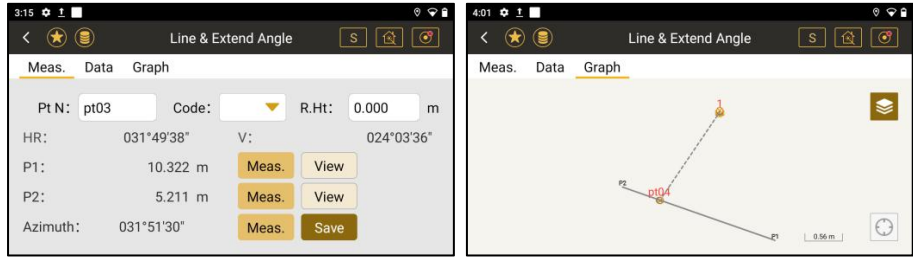

Keys	Description
[Meas.]	Measure points (P1, P2 and extend azimuth).
[View]	Check the coordinates for P1 and P2.
[Save]	Calculate and save the coordinates of extend point.

8.9 SAG MEASURE

Description

The sag measure is able to ensure the sufficient safety distance from the hanging cable to the ground, or to the object to be crossed.

The sag control and sag measure are calculated from measuring the horizontal distance of lower cable, the span or the observation of sag point.

Diagram

1. Sag Begin Method.

Set the station under one side of the tower (A).

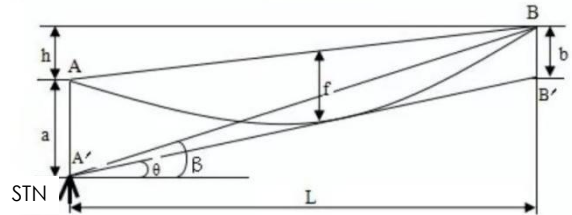

2. Sag In Method

Set the station between the location of two towers.

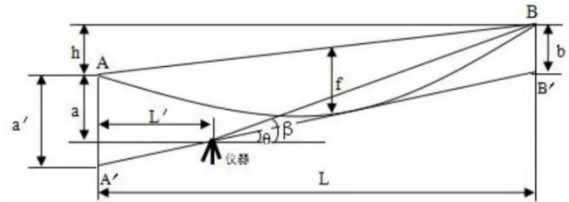

3. Sag Out Method

Set the station at the outside of two towers.

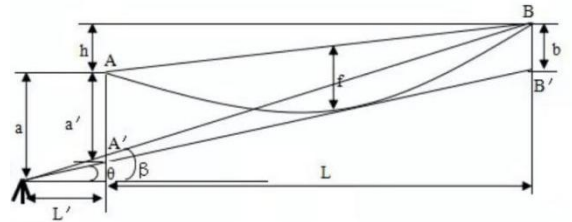

4. Sag Interval Method

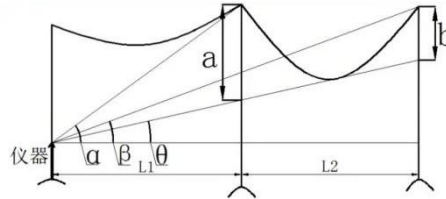

8.9.1 Sag Measure

Access

1) Select Main Menu: **[Collect] \ [Sag Measure]** Select the method.

Step-by-step

2) Enter or press **[Meas]** to measure the data for each item.

3) Press **[Calc.]** to calculate the observation angle of sag point (θ).

Sag Measure

The screenshot shows the 'Sag Measure' application interface. The title bar displays 'Sag Measure' and the time '10:44'. The interface includes a 'Legend >' link and several input fields with 'Meas' buttons:

- Sag Angle: Legend >
- Sag In Method: Span: 0.000 Meas m, Nominal Ht of Station: 0.000 Meas m
- Sag Out Method: Sag: 0.000 m, Value at Pulley (Clamp): 000°00'0" Meas
- Sag Interval Method: InsHt: 0.000 m

There are two buttons: 'g Control' and 'Calc.'.

Sag Begin

Item	Description	
Sag Angle	θ	Observation angle of sag (unknown)
Span	L	Distance of span
Sag	f	Sag value in the middle of span.
Nominal Ht of Station		= Nominal height - length of insulation string
Value of Pulley (Clamp)	β	Observation angle of pulley/clamp.

Sag In/Out

Item	Description	
HD of lower level	L'	Distance between the station to A.
Nominal Ht of Station		= Nominal height - length of insulation string
Value of Pulley (Clamp)	β	Observation angle of pulley/clamp.
Span	L	Distance of span
Sag	f	Sag value in the middle of span.

Sag Interval

Item	Description	
Span L1	L1	Distance of span.
Span L2	L2	Distance of span.
Sag	f	Sag value in the middle of span.
Angle α of lower level	α	the observation angle to the nearer pulley.

Angle β of lower level	β	the observation angle to the further pulley.
------------------------------	---------	--

8.9.2 Sag Control

Access

- 1) Select Main Menu: **[Collect]\[Sag Measure]\[Sag Control]**.
- 2) Select the method. Enter the instrument height.
- 3) Press **[Meas]** to measure. Press **[Calc.]** to calculate the sag value f.

8.10 TRAVERSE

8.10.1 Overview

Description

Traverse is used to establish a control point system when you have to work further than the first orientation or when the target is not visible. It needs at least two known points to open or end the traverse.

Types of traverse

1. Open Traverse. Apply for Roads, Railways, etc

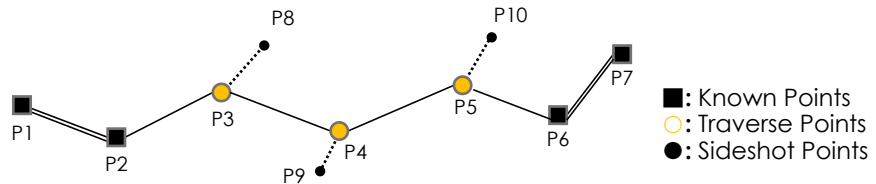

2. Closed Traverse, Apply for Buildings, Gardens, etc

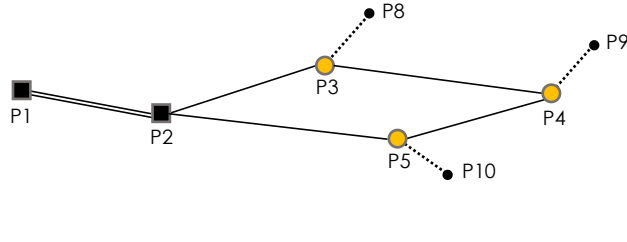

Access

Select Main Menu: **[Collect]\[Traverse]**

Sequence

B¹B²F²F¹	Backsight point is measured in face 1, face 2 order; Foresight point is measured in reverse order.
B¹B²F¹F²	Backsight point is measured in face 1, face 2 order; Foresight point is measured in same order.
B¹F¹B²F²	Backsight and foresight points are measured in face 1, then measured backsight and foresight again in face 2.
B¹F¹F²B²	Backsight and foresight points are measured in face 1, then reverse the order, foresight point is measured firstly in face 2.

8.10.2 Create a New Traverse

Access

Press **[+]**\Type the name**[OK]**

Traverse

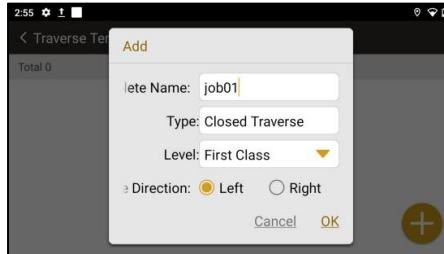

Traverse

Display	Description
Template Name	Name of the traverse.
Type	Traverse type, closed traverse or open traverse. The software will recognize it automatically.
Level	Select the measure level. (Refers to Appendix.C)
Angle Direction	The direction is in the left or right side of traverse.

8.10.3 Edit an Existed Traverse

Access

Press the traverse name \[Measure], [Edit] or [Delete] \[OK]

Traverse

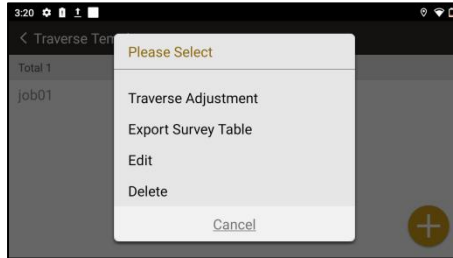

Display	Description
Measure	Continue the measurement of traverse points.
Traverse Adjustment	Adjust the results of traverse.
Export Survey Table	Export the data.
Edit	Edit the name of traverse.
Delete	Delete the data in this traverse.

8.10.4 Traverse Step in Step

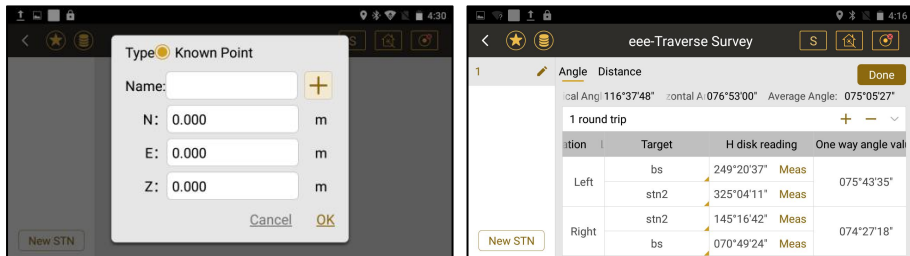

Step	Description
1	Setup total station at the first station (P2) which is known.
2	[New STN] to select or type the coordinates of first station (P2). [OK] to access the measure page for 1 st round.
3	[Target] to select the ID of backsight (P1) and foresight points (P3).
4	[Meas] to measure and record. (Measure sequence: B ¹ B ² F ¹ /B ¹ B ² F ¹ F ² /B ¹ F ¹ B ² F ² /B ¹ F ¹ F ² B ²)
	{Ang} \ {Dist} to check the data of traverse. Horizontal angle, calculated azimuth from the foresight to the backsight, distance measured by face1 and face 2 are displayed.

5	[+], [-] to add or delete the measure rounds.
6	Move to the foresight point (P3) as the next station.
7	[New STN] to type the name of traverse point. [OK] to access the measure page.
8	[Target] to select the ID of backsight (P2) and foresight points (P4).
9	[Meas] to measure and record. Move to the foresight point (P4) as the next station .
10	Repeat the steps to set the station at the other points (P4 ,P5). Then traverse is closed.
11	[Done] to save the data and back to the job list.

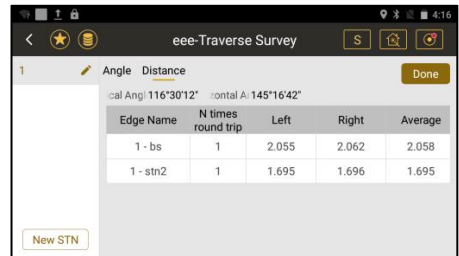
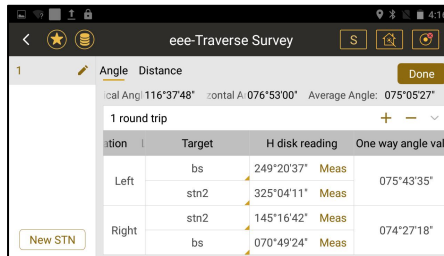

Page	Display	Description
------	---------	-------------

Angle	Vertical Angle	Horizontal angle of current position
	Horizontal Angle	Vertical angle of current position
	Average Angle	Average angle among several rounds
	1 round trip	Measure rounds.
	Location	Left: Face 1; Right: Face 2
	Target	Target ID for backsight and foresight.
	H Dist Reading	Horizontal angle of backsight & foresight (F1/F2)
	One Way Angle	Angle from foresight to backsight
	Round Trip Angle	Average angle in this round
Dist	Edge Name	Edge from backsight - station, station - foresight
	N Times Round	1 st , 2 nd , or 3 rd ... rounds
	Left	Distance in Face 1 (Left)
	Right	Distance in Face 2 (Right)
	Average	Average distance between F1 and F2

8.10.5 Traverse Adjustment

Description

A traverse adjustment can be performed on coordinates of traverse points, angles and distances.

Access

Traverse

Adjustment

Press the traverse name \[Traverse Adjustment]

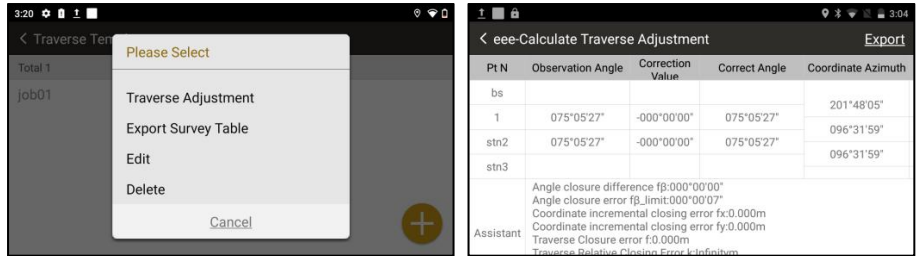

Traverse

Adjustment

Display	Description
Pt N	Point ID
Observation Angle	Original observed angle
Correction Value	Correction value of horizontal angle
Correct Angle	Corrected angle after adjustment
Coordinate Azimuth	Azimuth of each points
Distance	Distance between two points
Incremental Value	Incremental X and Y for traverse points
Corrected Increment	Corrected X and Y for traverse points
Last Coordinate	Coordinates for each points

8.10.6 Export Survey Table

Access

Press the traverse name \[**Export Survey Table**\] Select the location of storage \[**OK**\]

Default location: [**File manager**\] [**Internal Storage**\] [**com_southgns_surveystar Expand**\] [**Export**]. The file can be transferred by USB OTG, Bluetooth or Micro SD Card. Refers to Chapter 10.6.3

Survey Table

STN	Vertical Disk Location	Target	H disk reading	One way angle value	Round trip angle value	Average Angle
1	Face 1	bsc1	045°00'00"	164°22'38"	164°15'30"	164°15'30"
		3	209°22'37"			
	Face 2	3	029°09'05"	164°08'23"		
		bsc1	225°00'43"			
Edge Name	N times round trip	Face 1	Face 2	Average	Average value	
1-bsc1	1	10.555	10.550	10.553	10.553	
1-3	1	10.671	10.637	10.654	10.654	
3	Face 1	1	052°07'36"	205°09'13"	205°04'31"	205°04'31"
		4	257°16'49"			
	Face 2	4	077°17'56"	204°59'49"		
	1	232°18'08"				
Edge Name	N times round trip	Face 1	Face 2	Average	Average value	
3-1	1	10.686	10.675	10.680	10.680	
3-4	1	12.068	12.066	12.067	12.067	
4	Face 1	3	218°43'21"	333°23'45"	333°21'14"	333°21'14"
		5	192°07'06"			
	Face 2	5	012°02'27"	333°18'43"		
	3	038°43'44"				
Edge Name	N times round trip	Face 1	Face 2	Average	Average value	
4-3	1	12.095	12.100	12.098	12.098	
4-5	1	10.861	10.851	10.856	10.856	
5	Face 1	4	149°14'54"	208°28'05"	208°24'04"	208°24'04"
		1	357°42'59"			
	Face 2	1	177°35'12"	208°20'03"		
	4	329°15'08"				
Edge Name	N times round trip	Face 1	Face 2	Average	Average value	
5-4	1	10.824	10.805	10.815	10.815	
5-1	1	12.081	12.082	12.082	12.082	

8.11 CABLE HEIGHT

Description

This function is used to measure the height (**LH**) from a target (**L**) hanging in the air to the lower reference plane (**G**). (like the overhang of channel)

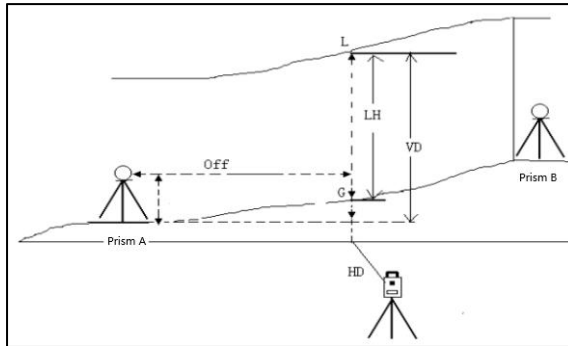

Access

Step-by-step

- 1) Select Main Menu: **[Collect]\[Cable Height]**
- 2) Press **[Setting]** to enter the instrument height and reflector height.
- 3) Press **[Meas]\[Save]** to measure prism A & B, define a reference plane.
- 4) Press **[Next]**, Aim at the target L, press **[Meas.]**.
- 5) Aim at the base point G on the ground, press **[Meas.]**.

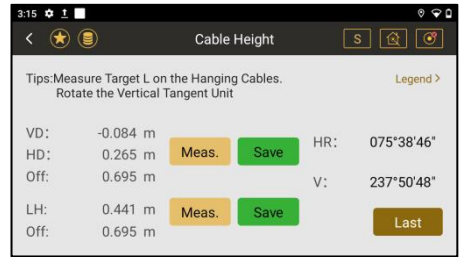
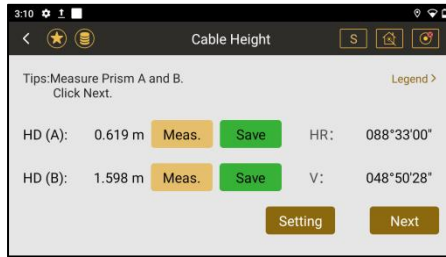

Item	Description
HD(A)	Horizontal distance to prism A.
HD(B)	Horizontal distance to prism B.
VD	Vertical distance from prism A to target L.
HD	Horizontal distance of target L.
Off	Offset between prism A and target L
LH	Height from target L to the ground G.

8.12 POINT PROJECTION

Description

It is used to calculate the coordinates of a point projected onto a line.

Diagram

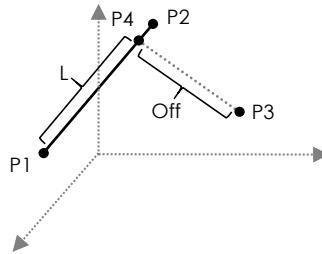

P1: Start Point
P2: End Point
P3: Measured Point
P4: Projected Point

Access

Step-by-step

- 1) Select Main Menu: **[COGO]\[Point Projection]**
- 2) Press **[+]**, select or measure two points to define a line. Press **[Next]**.
- 3) Press **[Meas]** to measure a point to be projected.
- 4) Press **[COGO]** to calculate projected coordinate. Press **[Data]** to check result.

Point Projection

Point Projection

StartPt: {[Meas.-]} + EndPt: {[Meas.-]} +

Nb1: 1.742 Nb2: -0.097

Eb1: 0.392 Eb2: 2.765

Zb1: 2.403 Zb2: 2.385 **Next**

Point Projection

Projection Point Data

HR: 346°12'02" Pt N: **Meas.**

V: 046°56'06" **Save**

N: 1.442 m Code: **COGO**

E: -0.354 m R.Ht: 0.000 m **Last**

Z: 2.387 m

Item	Description
Start Pt	Start point, defining a line.
Nb1/Eb1/Zb1	Coordinates of the start point.
End Pt	End point, defining a line.
Nb2/Eb2/Zb2	Coordinates of the end point.
N/E/Z	Coordinates of the measured point.
SD/VD/HD	Slope, vertical, horizontal distance of the measured point.

Result	Description
Np/Ep/Zp	Coordinates of the projected point.
L	Length from start point to projected point.
Off	Horizontal offset from measured point to projected point.
VD	Vertical distance from measured point to projected point.

9. STAKE OUT

9.1 OVERVIEW

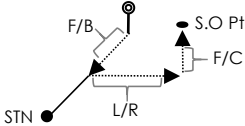
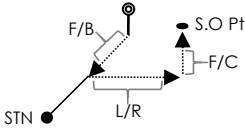
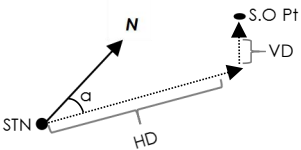
Description	Stakeout application is used to place marks or find locations in the field.	
Program	Diagram	
Point		<p>F/B: Forward / Backward L/R: Left / Right F/C: Fill / Cut S.O Pt: Selected, measured or typed by manual, which is known.</p>
CAD		<p>F/B: Forward / Backward L/R: Left / Right F/C: Fill / Cut S.O Pt: Selected from CAD files</p>
Angle & Distance		<p>α: Horizontal angle HD: Horizontal distance Z: Height difference\Vertical distance</p>

Direction Line

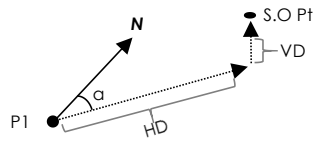

α : Horizontal angle\Azimuth

HD: Horizontal distance

Z: Height difference\Vertical distance

P1: Known.

Line

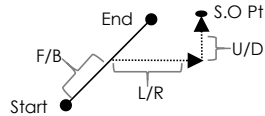

F/B: Forward / Backward

L/R: Left / Right

U/D: Up / Down

Start Pt & End Pt: Known

Reference Line

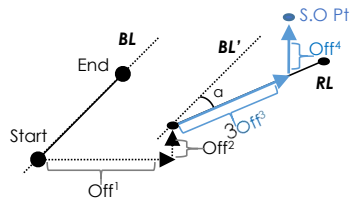

BL: Baseline, defined by two known points.

RL: Reference line, rotated (α) and moved by latitudinal (**Off¹**) and longitudinal (**Off²**) offset.

Off³: Left or right, backward or forward from the start point' of reference line.

Off⁴: Cut or fill from the start point'.

Arc S.O

Point

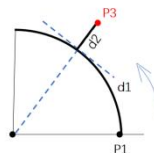

d1: Arc distance

d2: Radius distance (+)

P3: The point to be staked.

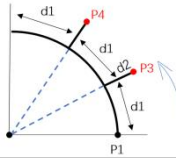
Arc**d1:** Arc length**d2:** Radius distance (+)**P3/P4...:** The points to be staked.

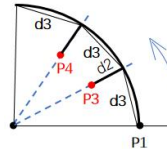
String**d3:** String length**d2:** Radius distance (-)**P3/P4...:** The points to be staked.

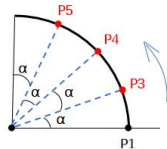
**Central
Angle** **α :** Central angle**d2:** Radius distance (0)**P3/P4/P5...:** The points to be staked.

9.2 POINT

Description The points can be selected from job, entered by manual or measured directly.

- Access**
- 1) Select Main Menu: **[Stake Out]\[Point S.O]\[+]**
 - 2) Rotate the telescope based on the guidance of E-compass, press **[Meas.]**
 - 3) When all the distance becomes 0, press **[Storage]**.

Point Stake Out

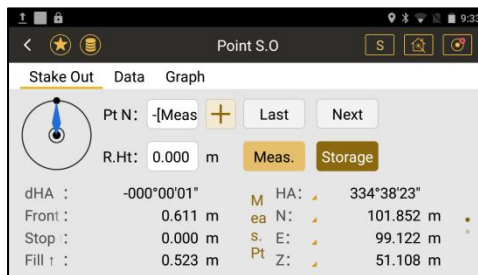

Display	Description
Pt N	Point ID to be staked.
E-Compass	Direction of the stakeout points.
dHA	Difference of horizontal angle
F/B	Forward or backward

L/R	Left or right
F/C	Fill or cut, move the target up or down.
P1	Display the HA/N/E/Z/HD/VD/SD of measured target.
P2	Slide the screen to check the information of points to be staked. Click the triangle mark to set the display items.
Keys	Description
[Last]	Last point to be staked.
[Next]	Next point to be staked.
[Meas.]	Measure the target.
[Storage]	Save the point into storage

9.3 CAD STAKE OUT

Description





The points to be staked can be uploaded and selected from DXF/DWG files.



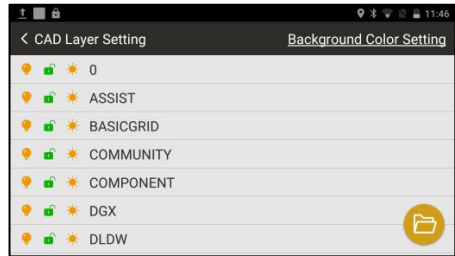
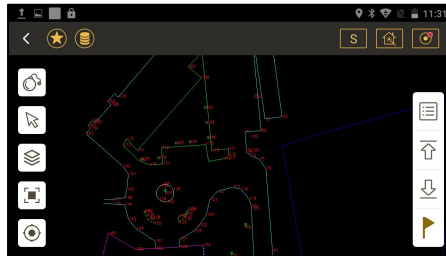

Access

- 1) Select Main Menu: **[Stake Out]\[CAD Stake Out]**.
- 2) Press   **[Done]** to upload the map in DXF/DWG files.

CAD Stake Out



Icons	Description
	Explore the features into sections.
	Select the features by cursor.
	Upload a map or layer in DXF/DWG files; Select the layer for display; Select the color of background.
	Display the full map.

	Locate the station.
	<p>Check all the lines. Select the line to be staked.</p> <p>Including 1) Line stake out, refers to Chapter 9.6 Line. 2) Start point stakeout, refers to Chapter 9.2 Point. 3) End point stakeout, refers to Chapter 9.2 Point. 4) start point extraction, and 5) end point extraction, to extract and save points.</p>
	Last
	Next
	<p>Select the feature, click it to stake out.</p> <p>Including 1) Line stake out, refers to Chapter 9.6 Line. 2) Start point stakeout, refers to Chapter 9.2 Point. 3) End point stakeout, refers to Chapter 9.2 Point. 4) Pile stake out, 5) Interval stakeout, 6) Offset stakeout.</p>

9.3.1 Pile Stakeout

Description Staking out the piles on the selected features.

- Access**
- 1) Select the feature, press **[F]** \ **[Pile Stake Out]**.
 - 2) Press **[↑]** \ **[↓]** to select the last or next pile.
 - 3) Press **[F]** again to stake out the selected pile.

Pile Stake Out







Icons	Description
Reverse	Reverse the stake out direction.
Exit	Exit the program.

9.3.2 Interval Stakeout

Description Staking out the points by the inputted interval.

Access

- 1) Select the feature, press  \ **[Interval Stake Out]**.
- 2) Enter the interval mileage, press **[Modify]**. It will calculate the location of points by the inputted interval, on the selected feature.
- 3) Press   to select the last or next point.
- 4) Press  again to stake out the selected point.

Pile Stake Out

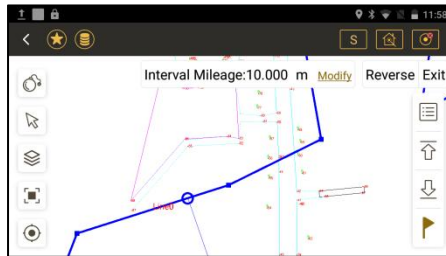

Icons	Description
Interval Mileage	Enter the intervals to be staked.
Reverse	Reverse the stake out direction.
Exit	Exit the program.

9.3.3 Offset stakeout

Description

Staking out the points by the inputted offsets.

Access

- 1) Select the feature, press **[F]** \ **[Offset Stake Out]**.
- 2) Enter the offsets, press **[Modify]**. It will move the selected feature horizontally for staking out.
- 3) Press **[↑]** **[↓]** to select the last or next point.
- 4) Press **[F]** again to stake out the selected point.

Pile Stake Out

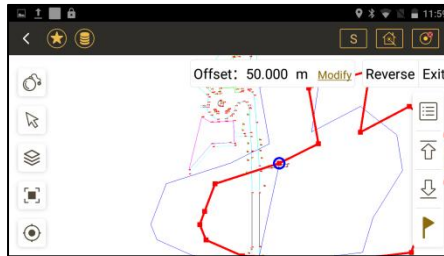

Icons	Description
Offset	Enter the offsets to be staked. Positive: Move right, Negative: Move left.
Reverse	Reverse the stake out direction.

9.4 ANGLE & DISTANCE

Description Stake-out the points by angle (HA), horizontal distance(HD) or height (Z).

Access 1)Select Main Menu:[Stake Out]\[Angle & Distance S.O]

2)Enter HA, HD, Z\[Next]\[Meas.]

Angle & Distance

Item	Value	Item	Value
dHA :	-000°00'05"	M HA :	359°59'55"
Back :	153.158 m	ea HD :	1.842 m
Left :	0.004 m	s. VD :	1.100 m
Dig l :	1.100 m	Pt Z :	51.100 m

Items	Descriptions
HA	Horizontal angle from stake out point to station.
HD	Horizontal distance from stake out point to station.
Z	Height difference from stake out point to station.

9.5 DIRECTION LINE

Description

Stake-out the points by angle (Azimuth), horizontal distance(HD) or height (VD), based on a known point, along the direction of azimuth.

Diagram

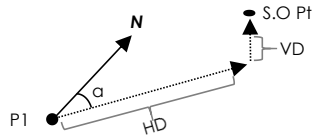

α: Azimuth

HD: Horizontal distance

Z: Vertical distance

P1: Known

Access

- 1) Select Main Menu: **[Stake Out] \ [Direction Line]**.
- 2) Enter the point ID, azimuth, HD and VD, press **[Next]**.
- 3) Stake out the points, press **[Meas] \ [Storage]**.

Direction Line

The screenshot shows a mobile application interface titled "Direction Line". At the top, there is a status bar with the time 3:59 and various icons. Below the title bar, there are three icons: a back arrow, a star, and a gear. The main content area is titled "Parameter" and contains four input fields: "Pt N:" with a plus sign button, "Azimuth:" with the value "000°00'00\"", "HD:" with the value "0.000" and a unit "m", and "VD:" with the value "0.000" and a unit "m". A "Next" button is located at the bottom right of the input fields.

Items	Descriptions
Pt N	Point ID of the known point.
Azimuth	Horizontal angle from stake out point to the known point.
HD	Horizontal distance from stake out point to the known point.
VD	Vertical difference from stake out point to the known point.

9.6 LINE

Description

The points are staked by a base line (defined by two known points) and the offset is calculated from the start point, move along the direction of baseline.

Diagram

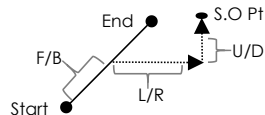

F/B: Forward / Backward

L/R: Left / Right

U/D: Up / Down

Start Pt & End Pt: Known points

Access

1) Select Main Menu: **[Stake Out] \ [Line]**

Step-by-step

2) Enter two points and offsets, press **[Next]**

3) Stake out the points, press **[Meas] \ [Storage]**.

Line Stake Out

The screenshot shows a mobile application interface titled "Line". At the top, there are navigation icons (back, home, search) and a status bar with the time 11:22. Below the title, there is a "Parameter" section with the following controls:

- StartPt: 1 (with a "+" button)
- EndPt: 2 (with a "+" button)
- Left/Right: Radio buttons for "Left" (selected) and "Right", followed by a text input field containing "20.000" and a unit "m".
- Front/Back: Radio buttons for "Front" and "Back" (selected), followed by a text input field containing "0.000" and a unit "m".
- Up/Down: Radio buttons for "Up" and "Down" (selected), followed by a text input field containing "0.000" and a unit "m".

A "Next" button is located at the bottom right of the parameter section.

Items	Descriptions
Start/End Pt	Define a line by two known points.
Left/Right	Longitudinal offset (Left or right).
Front/Back	Latitudinal offset (front or back).
Up/Down	Altitude offset (Up or down).

9.7 REFERENCE LINE

Description

Reference Line application can be used to stake out or measure points relative to a line.

The points are staked from a reference line (shifted from a baseline), and the

related offset.

The reference line can be offset either longitudinally or latitudinally to the baseline (defined by two known points), or be rotated around the first base point as required.

Diagram

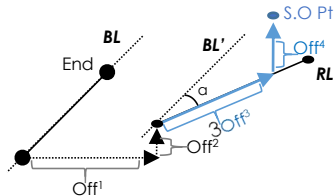

BL: Baseline, defined by two known points.

RL: Reference line, rotated (α) and moved by latitudinal (**Off¹**) and longitudinal (**Off²**) offset.

Off³: Left or right, backward or forward from the start point¹ of reference line.

Off⁴: Cut or fill from the start point¹.

Access

Step-by-step

Step 1. Define a baseline from two known points.

Press **[+]** to select, create, input or measure points.

Step 2. Define a reference line.

Type the offsets or angle to shift the baseline. Press **[Next]**.

Step 3. Stake out points

Enter the offsets from the start point of reference line, press **[Next]** to stake out the points.

Press **[Meas]** \ **[Storage]** to measure and save.

Reference line

4:00 Reference Line

Define Reference Line

StartPt: +

EndPt: +

Left/Right: 0.000 m

Front/Back: 0.000 m

Angle: +000°00'00" Next

Items	Descriptions
Start/End Pt	Define a baseline by two known points.
Left/Right	Longitudinal offset (Left or right) to define a reference line.
Front/Back	Latitudinal offset (front or back) to define a reference line.
Angle	This term must always be considered to mean as Bearing. The bearing angle from the baseline to define a reference line.
Up/Down	Vertical offset to define a reference line.

The screenshot shows a mobile application interface for setting stakeout parameters. The title bar reads 'Reference Line'. Below the title, there is a section titled 'Stakeout Parameters'. This section contains three input fields, each with a numerical value of 0.000 and a unit of 'm'. The fields are labeled 'Left/Right', 'Front/Back', and 'Up/Down'. A yellow 'Next' button is positioned to the right of the 'Up/Down' field.

Items	Descriptions
Left/Right	Longitudinal offset (Left or right) from the start point of reference line.
Front/Back	Latitudinal offset (front or back) from the start point of reference line.
Up/Down	Vertical offset from the start point of reference line.

Next Step

Stake out points (Refers to Chapter 9.2)

9.8 ARC

Description

Calculate and stake out the points related to an arc.

Elements that must be known to define the arc are:

- coordinate of central point
- coordinate of a start point

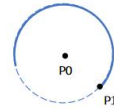

OR

- coordinates of start point and end point
- radius

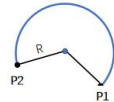

OR

- coordinates of three points on the arc.

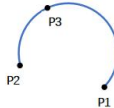

Access

1) Select Main Menu: **[Stake Out] \ [Arc S.O]**

Step-by-step

2) Define an arc by: Arc center & Start point; Two points & Radius; Three points.

Press **[Next]**.

3) Enter the offsets on the arc. Press **[Next]**.

4) Stake out the points, press **[Meas] \ [Storage]**.

Step 1.

Define an arc

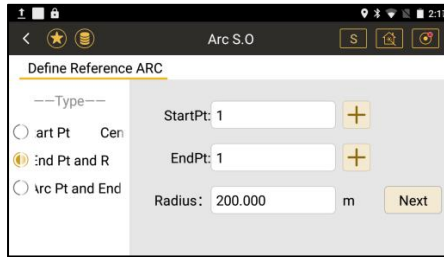

Methods	Descriptions
Center	Central point of the arc.
Start Pt	The start point of the arc. Available for define an arc using: Arc center & Start point, 3 points and 2 points & radius.
End Pt	The end point of the arc. Available for define an arc using: 3 points and 2 points & radius.
Arc Pt	The 3rd point of the arc. Available for define an arc using: 3 points.
Radius	The radius of the arc. Available for define an arc using: 2 points & radius.

Step 2:
Stake out an arc

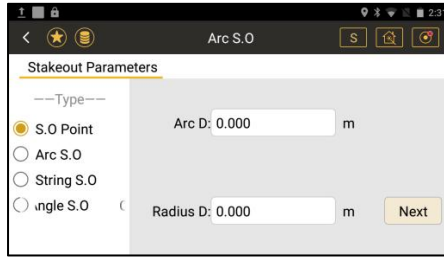

Methods	Elements Must Known	Diagram
Point	<p>Arc D ($d1$): Distance along the arc in anti-clockwise direction.</p> <p>Radius D ($d2$): Radius distance in ($d2 < 0$), on ($d2 = 0$) or outside ($d2 > 0$) the arc.</p>	
Arc	<p>Closed Differ:</p> <ul style="list-style-type: none"> ● Equally: Divide the closing error equally to each parts. ● End Pt: Add the closing error to the end point. ● Start Pt: Add the closing error to the start point. 	

	<p>Arc L (d_1): Divide arc into several parts by the arc length.</p> <p>Radius D (d_2): Radius distance in ($d_2 < 0$), on ($d_2 = 0$) or outside ($d_2 > 0$) the arc.</p>	
String	<p>Closed Differ: Equally, End Point or Start Point.</p> <p>String L (d_3): Divide arc into several parts by the string length.</p> <p>Radius D (d_2): Radius distance in ($d_2 < 0$), on ($d_2 = 0$) or outside ($d_2 > 0$) the arc.</p>	
Central Angle	<p>Closed Differ: Equally, End Point or Start Point.</p> <p>Center Angle (α): Divide arc into several parts by the angle.</p> <p>Radius D (d_2): Radius distance in ($d_2 < 0$), on ($d_2 = 0$) or outside ($d_2 > 0$) the arc.</p>	

Next Step

Stake out the points based on the arc.

(Refers to Chapter 9.2 Point.)

10. DATA MANAGEMENT

10.1 POINT MANAGEMENT

Overview

Item	Type	Code	N	E
22	Meas.Pt		111.198	111.198
21	Meas.Pt		113.021	113.021
1	Inp.Pt	stn	100.000	100.000

Field	Descriptions
Item	Point ID. Click the triangle to reorder the points.
Type	Display all or several types of points. e.g. Station point, measured point, inputted point, imported point, stake out point, known point, calculated point.
Code	Code of points.
N/E/Z	North, East and Zenith.
Time	Recording time.

10.1.1 Creating a New Point

Access

Select [📍]\{Data} page\{+}\Creating a new point\{OK}

Create a New Point

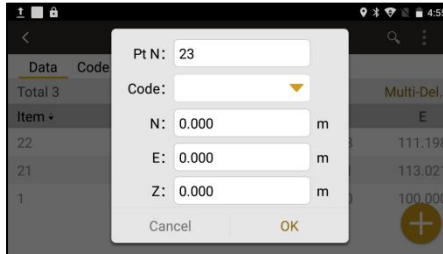

Field	Descriptions
Pt N	Name of the new point.
Code	Code of the new point. It can be selected from code list or typed by manual.
N/E/Z	North, east and zenith.

10.1.2 Editing a Point

Description

Edit the point ID or coordinates.

Access

Select [📍]\{Data} page\Select a point\{Edit}\{OK}

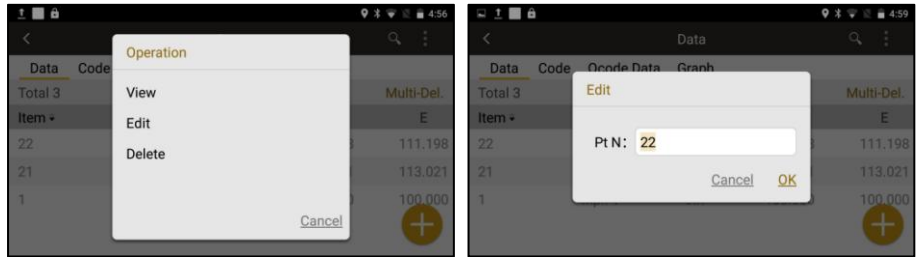

Type	Descriptions
Stn.Pt	Not editable.
Meas.Pt	Available to edit Pt N only.
Inputted Pt	Available to edit Pt N, code and coordinates.
Imp. Point	Available to edit Pt N, code and coordinates.
S.O Point	Not editable.
Known Pt	Available to edit.
Calc.Pt	Available to edit Pt N, code and coordinates.

10.1.3 Deleting Points

Access

Points can be deleted by three methods:

- Single: Select a point\ **[Delete]**
- Multiple: Press **[Multi-Delete]**\ Tick the points\ **[Delete]**
- All: Press **[⋮]** \ **[Clear]**

Delete Points

Data	Code	Qcode	Data	Graph
Cancel			2 Selected	Delete
<input type="checkbox"/> Item +	Type	Code	N	E
<input checked="" type="checkbox"/> 23	Stn.Pt	station	30.000	0.000
<input checked="" type="checkbox"/> 23	Inp.Pt	stn	30.000	0.000
<input type="checkbox"/> 22	Meas.Pt		111.198	111.198
<input type="checkbox"/> 21	Meas.Pt		113.021	113.021
<input type="checkbox"/> 1	Inp.Pt	stn	100.000	100.000

10.1.4 View Points

Access

Select **[📍]** \ **{Data}** page \ Select a point \ **[View]**.

Including point name, type, code, R.ht, HA, VA, N, E, Z, HD, dVD and SD.

10.1.5 Searching a Point

Access

Press **[🔍]** \ Type the keyword of point name \ **[Enter]**

10.2 CODE MANAGEMENT

Access

Select [] \{Code} page



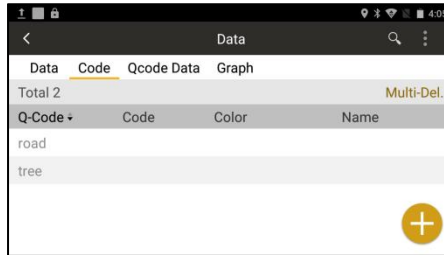

Overview



Q-Code	Code	Color	Name
			road
			tree

Display	Description
Q-Code	Quick code, must be created in Southmap or CAD. Otherwise, please enter the full code here to record the codes in raw data or coordinate data. Maximum 16 digits.
Code	Code, which is created in southmap or CAD.
Color	Color, which is created in southmap or CAD.
Name	Note, which is created in southmap or CAD.

**Code
Management**

Operate	Access
Create	[+] \Type the information \[OK]
Edit	Select a code \[Edit] \[OK]
Delete	Select a code \[Delete]. [Multi-Del.] \Tick the codes \[Delete]. Press [] \[Clear].
Search	Press [] \Type the keyword of codes \[Enter]
Import	Press [] \[Import Code]. Refers to Chapter 10.5.2.
Export	Press [] \[Export Code]. Refers to Chapter 10.6.2.



10.3 QCODE MANAGEMENT

Quick codes must be created in Southmap or CAD.

10.4 MAP MANAGEMENT



Description Upload the map or layers for graphical display.

Access

- 1) There are two methods to access map.
 - Press [] from the tool bar \{Graph} page.
 - Select Main Menu: [Measure]\{Graph} page.
- 2) Press [] to access the map management.

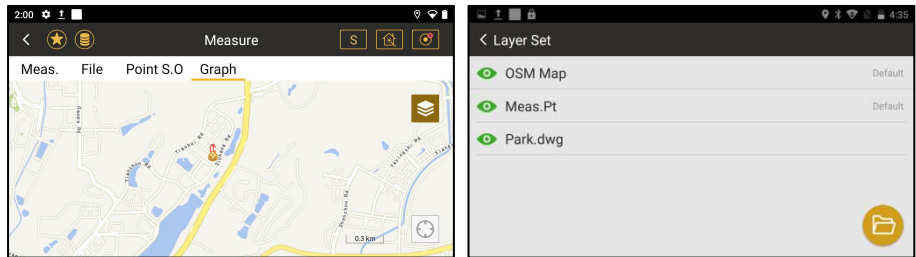
Map Page



Keys	Description
	Change the layers screen.
	Make layers from the CAD file visible or invisible in map.
	Select a CAD file or offline map to the job.

10.5 IMPORT DATA

Description

The data to import must be stored in the internal memory.

Formats

Type	File Extension
Coordinate	*.txt, *.dat
Code	*.xls
Map	*.map, *.mbtiles, *.kml, *.shp, *.dwg, *.tif, *.tiff, *.dxf
CAD Stake Out	*.dwg, *.dxf
Road	*.rd, *.ip, *.xlsx, *.rod, *.pm, *.jd

10.5.1 Importing Coordinates

Description

Point Name,code,N,E,Z

Example: imp5,building,-0.286,29.757,1.424

imp2,tree,29.757,-0.286,1.424

Access

1) Press  in tool bar \{Data} Page \[ \ [Import].

Step-by-step

- 2) Select type (*.txt or *.dat) and file from the internal memory.
- 3) Select and drag the item (Pt N, Code, N, E, Z) to change the imported order.

Import Coordinates

4) Press [OK]

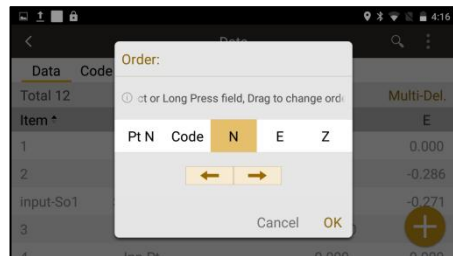
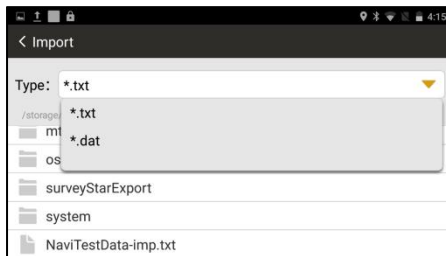

Keys	Descriptions
Type	All files with extension *.txt and *.dat can be selected.
ESC	Escape to the root directory.
Back	Back to the last page.
←/→	Change the order of data.
OK	To import the data.
Cancel	To exit the screen.

10.5.2 Importing Codes

Description

Example:

Q-code	Code	Color	Name
K05	204201	1	

(Header Lines to be skipped)

Access

- 1) Press  in tool bar \{Code} Page \[...]\[Import Code].
- 2) Select type (*.xls) and file from the internal memory.

Import Codes

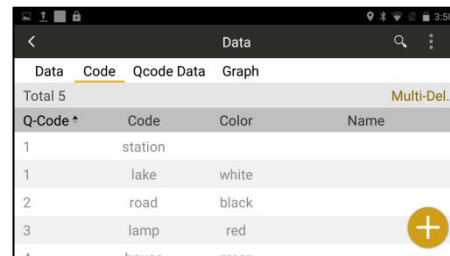

Keys	Descriptions
Type	All files with extension *.xls can be selected.
ESC	Escape to the root directory.
Back	Back to the last page.

10.5.3 Importing Maps

Description In normal, when instrument is online, the map will be loaded automatically. Meanwhile, the layers and maps can be imported for offline users.
*It is a kind of reference in work, the deviation might be existed.

- Access**
- 1) Press [📁] in tool bar\{**Graph**} Page.
Or select main menu: [**Measure**]\{**Graph**} page.
 - 2) Press [📁] \ [📁] to select a CAD file or offline map to the job.
 - 3) Choose type and file from the internal memory. Press [**Done**].

Import Maps

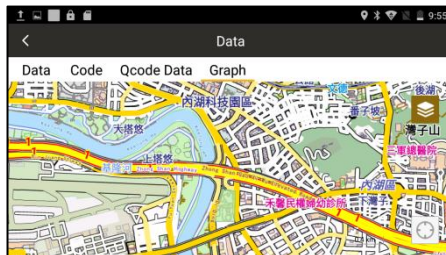
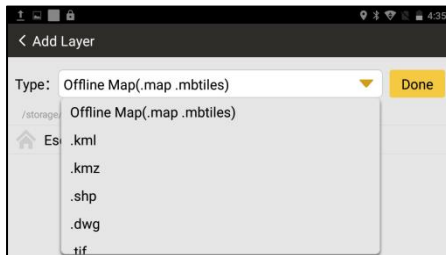

Type	Description
*.map, *.mbtiles	Map related files
*.kml	Map related files



*.kmz	Map related files
*.shp	Shape files
*.tif, *.tiff	Tagged image files
*.dxf	Drawing exchange files
*.dwg	Drawing files

10.5.4 Importing Data for CAD Stake Out

Description

Easy-to-Stake out the base map from a CAD file. Refers to Chapter 9.3.

Access

- 1) Select main menu: **[Stake Out]\[CAD Stake Out]**.
- 2) Press [ | \ [] to select a CAD file to the job.
- 3) Choose type (DWG/DXF) and file from the internal memory. Press **[Done]**.

Import Data for CAD Stake Out

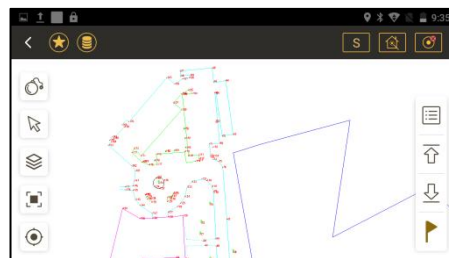
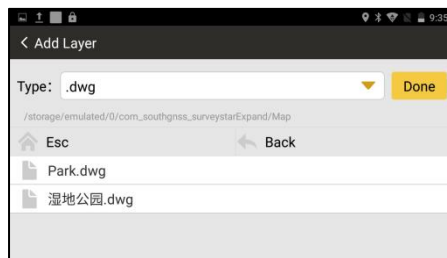

Keys	Descriptions
Type	All files with extension *.dwg and *.dxf can be selected.
ESC	Escape to the root directory.
Back	Back to the last page.

10.6 EXPORT & COPY DATA

Description

The data can be exported to the internal memory.

Copy it to the data storage device (Micro SD card, USB OTG) or transfer it by Bluetooth.

Overview

Type	File Extension	
Points	Coordinate	*.txt, *.dxf, *.dat, *.csv, *.txt (FC-6/GTS-7)
	Raw Data	*.txt, *.txt (FC-6/GTS-7)
	Side & Angle Data	*.txt
Codes	*.xls	
Traverse	*.xls	

Next Step

Please check the data format in Appendix B.

10.6.1 Exporting Points

Access

1) Press **[☰]** \{Data} Page \ **[⋮]** \[Export].

Step by Step

2) Press **[Export]** to export the ticked data.

3) Enter the file name, select the type and format.

4) Select the saving location, press **[OK]**

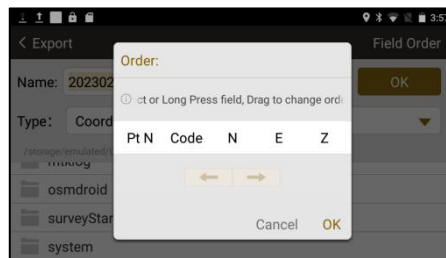
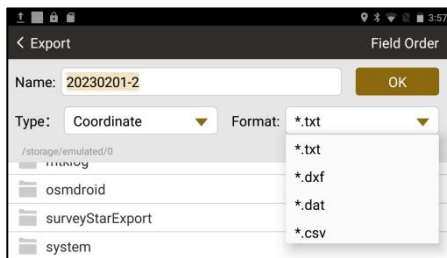

Item	Description
Name	File name to be saved in internal memory.
Type	Coordinate, raw or side & angle.
Format	Select the format of data
[ESC]	Escape to the root directory.
[Back]	Back to the last page.

[Field Order]	Change the order of exported data.
[OK]	Save and export.

Next Step

Copy to external devices (Chapter 10.6.3)

10.6.2 Exporting Codes

Access

1) Press  \{Code} Page \{  } \[Export Code].

Step by Step

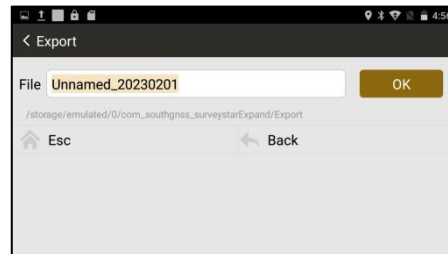
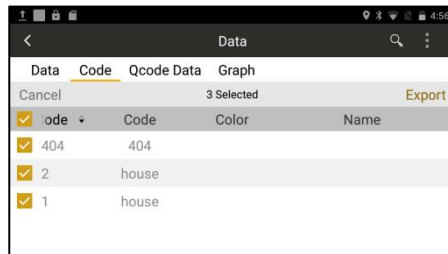

- 2) Press **[Export]** to export the ticked data.
- 3) Enter the file name.
- 4) Select the saving location.
- 5) Press **[OK]**.



Next Step

Copy to external devices (Chapter 10.6.3)

10.6.3 Copy to External Devices

Description	The files in the internal memory can be transferred to another device by Micro SD card, USB OTG or Bluetooth.	
Access Step by Step	1. Micro SD	1) Insert a micro SD card or USB OTG. 2) Select [File Manager] . The data will be saved in [InternalStorage]\[com_southgnss_surveystarExpand]\[Export] in default.
	2. USB OTG	3) Press the file until it is colored and selected. 4) Press [] to copy the file. 5) Back to the location of external device. 6) Press [] to paste it.
	3. Bluetooth	1) Select [File Manager] . 2) Press the file until it is colored and selected. 3) Press []\ [Bluetooth] to select and connect your Bluetooth device. 4) Confirm the Bluetooth Connection Request, 5) Press [Yes]\[OK] to receive the data from total station.

11. COGO

Program	Description
Reduction	To convert the local coordinates to real coordinates.
Traverse Adjustment	To adjust the traverse.
Calc.XYZ	To calculate the position of new points using the azimuth, bearing and distance from a known point.
Inverse	To calculate the angle and distance differences between two known points.
Area & Girth	To calculate the area and girth linked by points.
Included Angle	To calculate the included angle from three points.
Dist. Conversion	To convert the unit of distances.
Angle Conversion	To convert the unit of angles.
Average	To compute the average for coordinate.
Equidistant Point	To calculate the equidistant points between two known points.
Triangle Calc.	To calculate a triangle by angles or sides.
Calculator	Calculator.

11.1 REDUCTION

Overview

Reduction is used to convert the local coordinates to the real coordinates.

- 1) Free station. Refers to Chapter 7.7.
- 2) Station setup without CP. Refers to Chapter 7.8.

11.1.1 Reduction for Free Station

Access

- 1) Choose station ID. Press **[Reduction]**.
- 2) Press **[Call]** or **[Input]** to select backsight.
- 3) The local coordinates will convert to the real coordinates.

Reduction for Free Station

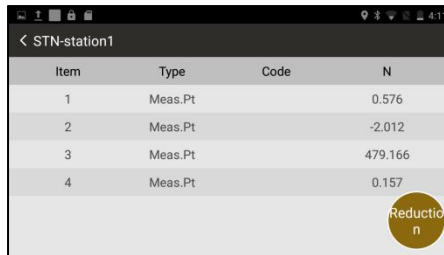

The screenshot shows a mobile application interface for 'STN-station1'. It displays a table with four rows of measurement points. The 'N' column shows local coordinates. A yellow circular button labeled 'Reduction' is overlaid on the bottom right of the table.

Item	Type	Code	N
1	Meas.Pt		0.576
2	Meas.Pt		-2.012
3	Meas.Pt		479.166
4	Meas.Pt		0.157

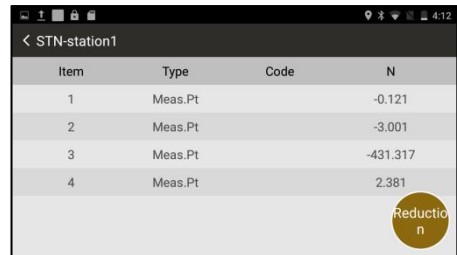

The screenshot shows the same 'STN-station1' screen after the reduction process. The 'N' column now displays real coordinates. A yellow circular button labeled 'Reduction' is overlaid on the bottom right of the table.

Item	Type	Code	N
1	Meas.Pt		-0.121
2	Meas.Pt		-3.001
3	Meas.Pt		-431.317
4	Meas.Pt		2.381

The coordinates will be changed after reduction.

11.1.2 Reduction for Station Setup without CP

Access

- 1) Input station ID and a public point.
- 2) Press **[COGO]\[Save]** to convert the coordinates.

Reduction for STN Setup without Control Point

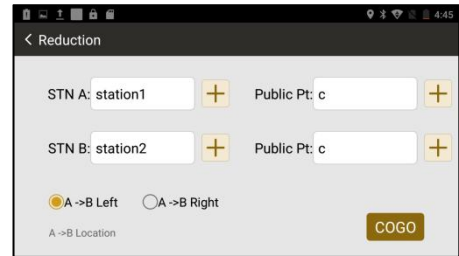
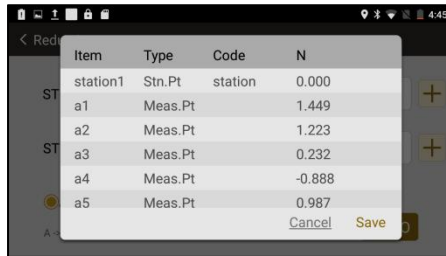

Item	Descriptions
STN A	Select the point ID of the first station.
STN B	Select the point ID of the second station.
Public Pt	Select the point ID of the public point.
A → B Left	The public point C is on the left side of A → B
A → B Right	The public point C is on the right side of A → B
COGO	Calculate

11.2 TRAVERSE ADJUSTMENT

Refers to Chapter 8.10.5 Traverse Adjustment.

11.3 CALC. XYZ

Description

Calculate XYZ, as known as Traverse in COGO.

To calculate the position of new points using the azimuth, bearing and distance from a known point.

Access

- 1) Select Main Menu: **[COGO]\[Calc.XYZ]**
- 2) Press **[+]**, select point ID. Enter the azimuth, bearing and distance.
- 3) Press **[COGO]\[Save]**.

Calc.XYZ

The screenshot shows the 'Calc. XYZ' application interface. At the top, there is a back arrow and the text '< Calc. XYZ'. Below this, there are two tabs: 'Calc.XYZ' (selected) and 'Graph'. The main area contains several input fields and a result display. On the left, there is a 'StartPt:' field with the value '1'. To its right is a yellow '+' button. Below this are three rows of input fields: 't Angle:' with '040°00'00"', 'n Angle:' with '090°00'00"', and 'HD:' with '20.000' m. Below these are 'VD:' with '5.000' m. On the right side, there is a 'Result' section with three rows: 'N:' with '-10.947 m', 'E:' with '16.675 m', and 'Z:' with '6.201 m'. At the bottom right, there are two buttons: 'COGO' and 'Save'.

Item	Descriptions
Start Pt	Point ID of a known point.
Azimuth	Azimuth of the known point.
Bearing	Bearing from the known point
HD	Horizontal distance (offset)
VD	Vertical distance (offset)
N/E/Z	Coordinate of the calculated point

11.4 INVERSE

Description

To calculate the angle and distance differences between two known points.

Access

- 1) Select Main Menu: **[COGO]\[Inverse]**.
- 2) Press **[+]**, select point ID. Press **[COGO]**.

Inverse

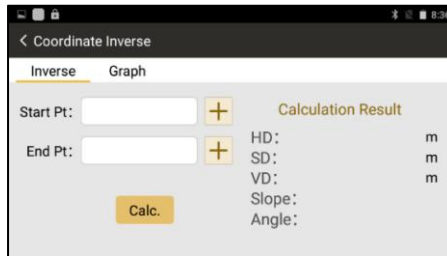

Coordinate Inverse

Inverse Graph

Start Pt: + Calculation Result

End Pt: +

HD: m

SD: m

VD: m

Slope:

Angle:

Calc.

Item	Descriptions
HD/SD/VD	Horizontal, slope and vertical distance between 2 points.
Slope	Slope differences between 2 points.
Angle	Angle differences between 2 points.

11.5 AREA & GIRTH

Description

The application program Area is used to compute areas and girth of points connected by straights. The calculated area is projected onto the horizontal plane.

Access

- 1) Select Main Menu: **[COGO]\[Area & Girth]**
- 2) Press **[Add]**, the points can be measured, selected from memory or entered by manual.
- 3) Press **[COGO]**.

Area & Girth

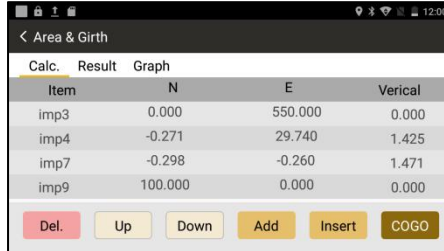

The screenshot shows a mobile application interface titled "Area & Girth". At the top, there is a navigation bar with a back arrow and the title. Below the navigation bar is a table with columns: "Calc.", "Result", and "Graph". The table has four rows of data, each representing a point (imp3, imp4, imp7, imp9). The columns are further divided into "Item", "N", "E", and "Verical". Below the table, there are several buttons: "Del.", "Up", "Down", "Add", "Insert", and "COGO".

Calc.	Result	Graph		
Item	N	E	Verical	
imp3	0.000	550.000	0.000	
imp4	-0.271	29.740	1.425	
imp7	-0.298	-0.260	1.471	
imp9	100.000	0.000	0.000	

Keys	Descriptions
Del.	Delete the selected point.

Up/Down	Move the selected data up or down.
Add	Add a new point.
Insert	Insert a new point before the selected point.
COGO	Calculation.

11.6 INCLUDED ANGLE

Description

To calculate the included angle from three points.

Access

- 1) Select Main Menu: **[COGO]**\[Included Angle]
- 2) Press **[+]** to add the points. Press **[COGO]** to calculate $\angle BAC$.

Included Angle

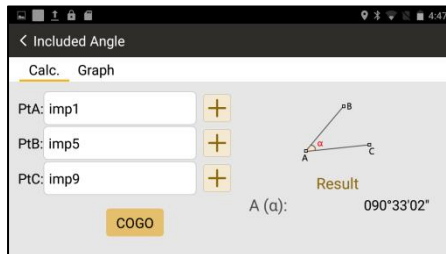

11.7 DISTANCE CONVERSION

Description	To convert the distance unit.
Access	1) Select Main Menu: [COGO]\[Dist.Conversion] 2) Press [▼] to select the unit, enter the value of distance to convert the units among km, m, cm, mile, yard, feet, inch. 3) Press [Conversion] .

11.8 ANGLE CONVERSION

Description	To convert the angle unit.
Access	1) Select Main Menu: [COGO]\[Angle Conversion] 2) Press [▼] to select the unit, enter the value of distance to convert the units among radian, degree and DMS. 3) Press [Conversion] .

11.9 AVERAGE

Description To compute the average for coordinate.

Access 1) Select Main Menu: **[COGO]\[Average]**
2) Press **[Add]\[COGO]**.

Average

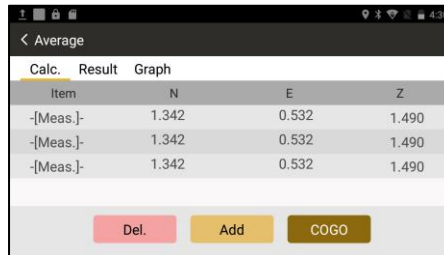

Calc.	Result	Graph
Item	N	E Z
-[Meas.]	1.342	0.532 1.490
-[Meas.]	1.342	0.532 1.490
-[Meas.]	1.342	0.532 1.490

Del. Add COGO

11.10 EQUIDISTANT POINT

Description To calculate the equidistant points between two known points.

Access 1) Select Main Menu: **[COGO]\[Equidistant Point]**.
2) Press **[+]** to add a start point and an end point. Enter the intervals.

3) Press **[COGO]\[Save]**

Equidistant Point

The screenshot shows a mobile application interface for calculating an equidistant point. The title is "Equidistant Point" with a back arrow. There are two tabs: "Calc." (selected) and "Graph". Under "Calc.", there are input fields for "PtA: imp1", "PtB: imp4", and "Interval Pt: 5". Each input field has a "+" button to its right. Below the inputs are "Save" and "COGO" buttons. On the right side, there is a diagram showing two points, A and B, with a series of red dots representing the path between them. Below the diagram, the word "Result" is displayed. At the bottom right, the calculation results are shown: "P1", "N:", and a value of "-0.045 m".

11.11 TRIANGLE CALCULATION

Description

To calculate a triangle by angles or sides.

Access

- 1) Select Main Menu: **[COGO]\[Triangle Calc.]**.
 - 2) Select the method (S/S/S, S/A/S, S/A/A, A/S/A, P/P/P), and press **[COGO]**.
 - S: Sides,
 - A: Angles,
 - P: Points
-

Triangle Calculation

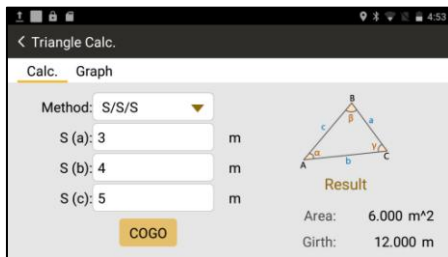

11.12 CALCULATOR

Description

Calculator.

Access

Select Main Menu: **[COGO]**\[Calculator].

Calculator

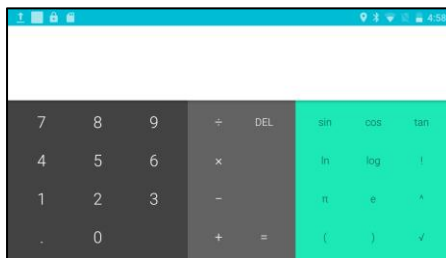

12. ROAD

12.1 ROAD DESIGN

12.1.1 Overview

Description

Design or import the design of roads by intersections.

Access

To Create: Select **[Program]\[Road]\[+] \[New]**\Enter Name.

To Import: Select **[Program]\[Road]\[+]\[Import]** to import files. Available in:
*.rd-EG Star, *.ip-EG Star, *.xlsx-Road Elements Form, *.rod-EG Star, *.pm
and *.jd.

To Edit: Select **[Program]\[Road]**\Click the road in list**[Open]**.

To Delete: Select **[Program]\[Road]**\Click the road in list**[Delete]**.

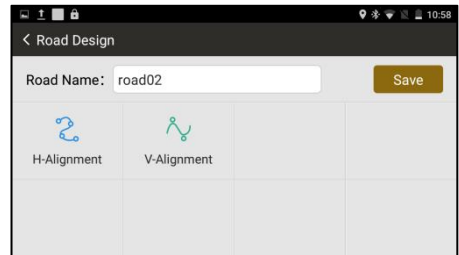
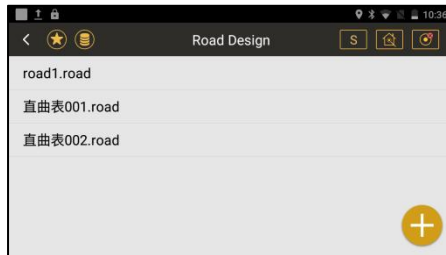

Next Step

When manually typing a road in your total station, the horizontal and vertical

alignment are used for road design. Select **[H-Alignment]** and **[V-Alignment]**.

12.1.2 Design a Road - Horizontal Alignment

Description

The horizontal alignment is designed by intersection points, there are Start Point, Intersection Points and End Point.

Horizontal Alignment

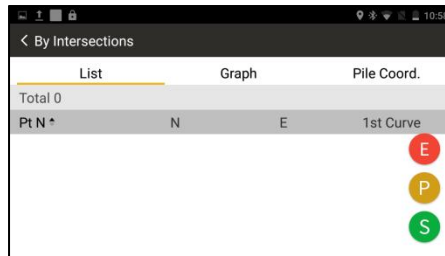

Keys	Descriptions
[S]	Start point. Including N, E and Start Mile.
[P]	Intersection point. Including Point ID, N, E, Rs (Start radius for the 1 st transition curve), 1 st Transition Curve, Radius, 2 nd transition curve, Re (End radius for the 2 nd transition curve).
[E]	End point. Including N and E.

[S] Start Point

Item	Descriptions
N	N (X) coordinates
E	E (Y) coordinates
Start Mile	Start mile of the road

[P]

Intersection Points

Item	Descriptions
Intersection	Point ID of intersection points
N	N(X) coordinates
E	E(E) coordinates
Rs	Start radius of 1 st transition curve.
1 st Trans Curve	Length of the 1 st transition curve.
Radius	Radius of the arc.
2 nd Trans Curve	Length of the 2 nd transition curve.
Re	End radius of the 2 nd transition curve.

In normal, road includes three elements in horizontal alignment. They are transition curve, arc and straight line.

How to enter the elements (e.g. transition curve, arc and straight line) by intersections?

1) Transition Curve:

If the transition curve is connected after a straight line, $R_s = \infty$;

If the transition curve is connected before a straight line, $R_e = \infty$

2) Arc:

$R_s = \infty$, $R_e = \infty$, 1st Trans Curve = 0, 2nd Trans Curve = 0.

Only Point ID, N, E, Radius are valid for entry.

3) Straight Line:

Only Point ID, N and E are valid. It will calculate the azimuth automatically.

[E] End Point

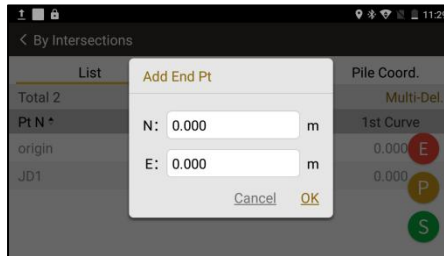

Item	Descriptions
N	N (X) coordinates of end point
E	E (Y) coordinates of end point

12.1.3 Design a Road - Vertical Alignment

Description

Creating, editing and deleting the vertical alignment.

Access

Arc Method

Select **[V-Alignment]**\ **[+]**\ Enter the mile and height\ **[OK]**

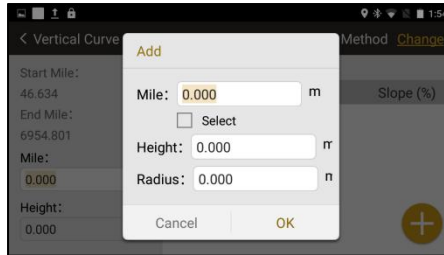

Item	Descriptions
Mile	Mile of the current segment.
Height	Height of the current segment.
Radius	Radius of the current segment. If it is the first mile, leave it as 0.

Parabolic Method

Press **[Change]** to change the method between arc and parabolic arc methods.

Parabolic Arc Method allows a smooth transition between the existing curve shifting to the next part.

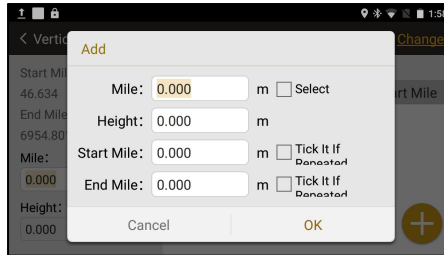

Item	Descriptions
Mile	Mile of the current segment.
Height	Height (elevation) of current segment.
Start Mile	Last mile in the parabolic.
End Mile	Next mile in the parabolic.

Next Step

Road Stake Out.

12.2 ROAD STAKE OUT

Description

Stake out the middle line, left and right pile on the designed road.

Access

Select Main Menu **[Program] \ [Road S.O]** \ Select a road.

Stake Out

The screenshot shows the 'Road S.O.' application interface with the following fields and values:

- Start Mil: 0.000 m
- End Mil: 30618.915 m
- Full:
- Mid CH: Calc. (dropdown)
- Interval: 100.000 m
- Left CH: Calc. (dropdown)
- Left offset: 1.000 m
- Right CH: Calc. (dropdown)
- Right offset: 1.000 m
- Calc. button

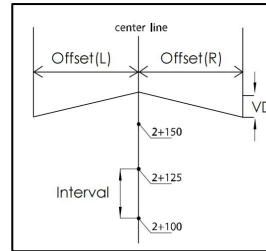

Item	Descriptions
Full	When it is activated, the points to be staked will be calculated from the full road (from start mile to the end). When it is not activated, the points to be staked can be selected by manual. For example, from 1000m to 2000m.
Start Mile	The starting mile for stake out.
End Mile	The ending mile for stake out.

Mid CH	Selectable item. To select whether to calculate the coordinates of chainage on the center line of road.
Interval	Interval (chainage increment) between stake-out points
Left CH	Selectable item. To select whether to calculate the coordinates of left chainage or not.
Left Offset	Left offset, calculated from the center line.
Right CH	Selectable item. To select whether to calculate the coordinates of right chainage or not.
Right Offset	Right offset, calculated from the center line.

Next Step

Check the calculated points (including points on the center line, left and right chainage with offset) for stake out.

Stake Out Points

Mid CH	Left CH	Right CH	
Total 374			Multi-Del.
Pile No. *	N	E	Deisgned Ht
K0+000.000	2789733.311	518680.341	0.000
K0+056.005	2789732.106	518624.351	0.000
K0+100.000	2789732.453	518580.359	0.000
K0+112.010	2789732.745	518560.353	0.000

Main CH
 Added CH
 CH w/o Interval

Item	Descriptions
{Mid CH}	Point list for chainage on the center line.
{Left CH}	Point list for left chainage, with left offset.
{Right CH}	Point list for right chainage, with right offset.
Main CH	When it is checked, only main chainage will be shown.
Added CH	When this box is checked, only the chainage which added by manual will be shown.
CH w/ Interval	When this box is checked, only the chainage with intervals (increment) will be shown.
	Add points to be staked by manual.
	Select a point, press it to stake out.

13. SETTING

Items		Options
Unit	Angle Unit	Degree/Gon/Mil/DMS (Degree Minute Second)
	Distant Unit	M/US.Feet/International Feet/US. Feet-Inch
	Temperature Unit	°C/°F
	Pressure Unit	hPA/mmHg/inHg
Angle	Min. Angle Reading	5"/1"/0.1"
	V0	H0/V0/±90/Slope
	HL/HR	Horizontal left/Horizontal right
	Compensator	Off/X-Axis(Single)/XY-Axis(Dual)
Distance	Min. Distance Reading	1 mm/0.1mm
	Coefficient (k)	Refraction coefficient. 0.14/0.2/Close.
	Scale Factor	1.0 in default.
	Average Elevation	0.000 in default.
	Temperature	20.000 °C in default.
	Pressure	1013.000 hPA in default.
	PPM	The atmospheric ppm is either set or calculated from

		the values in the previous fields.
	Measure Mode	N Times/Continuous/Tracking/Single
	Target	Non-prism/Sheet/Prism
Coordinate	Display Order	NEZ/ENZ
Comm.	Demo Mode	Simulating the data without measurement.
Adjustment	I Angle Set	Refers to Chapter 14.8
	E Bubble Adjust	Adjust the e-bubble. Refers to Chapter 14.3
	2C Set	Adjust the perpendicularity between sight of view and horizontal axis. Refers to Chapter 14.5
	Combine	Combine the adjustment of i-angle, 2C and e-bubble in once. Refers to Chapter 14.9
	H-Axis Error	Adjust the perpendicularity between vertical and horizontal axis. Refers to Chapter 14.6
	Parameter	Set the additive constant and instrument constant K. Refers to Chapter 14.10
	Error Display	Error display, including i-angle, 2C and H-Axis.
Others	Reticle Backlight	On or Off
	Soft-Keypad	On or Off

	EDM Beep	On or Off
	Measure Beep	On or Off
	Repeat Roll Call	On or Off
	Q-Code	On or Off, designed in Southmap.
Function Key		The measure button and the numeric keys are able to be defined by user. Refers to Chapter 3.7
Reset to Default		Reset the total station to default settings.
About	Update	Click to check and update the latest software.
	Software Information	Check the software version and copyrights.

14. INSPECTION & ADJUSTMENT

The instrument has passed the procedure of inspection and adjustment before releasing to the market, which ensures that it meets quality requirement. However, after long periods of transportation or the changeable environment, some influences may occur to the internal structure. Before the first operation, the user should check and adjust the functions to ensure the precision of the job.

14.1 PLATE VIAL

Inspection

Loosen the horizontal tangent screw, rotate the equipment to ensure that the plate vial is parallel to the direction of foot screw AB. Adjust the screw A/B in opposite direction to move the bubble in the center. Rotate the instrument to 180° to see whether the bubble is in center, if not, the plate bubble needs to be adjusted.

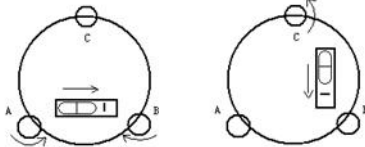

Adjustment

1. If the bubble of the plate vial moves away from the center, bring it half way back to the center by adjusting the screws, which is parallel to the plate vial. Correct the remaining half by adjusting pin.
2. Rotate the instrument in 180° to check whether the bubble is in the center. If not, repeat Step 1.
3. Rotate the instrument in 90° , adjust the third screw. Repeat the steps until the bubble remains in the center in any direction.

14.2 CIRCULAR VIAL

Inspection

It is not necessary to adjust the circular vial, except the bubble is not in the center after the adjustment of plate vial.

Adjustment

If the bubble of the circular vial is not in the

center, adjust the bubble to the center by using the adjusting pin or hexagon wrench.

First, loosen the screw opposite to the offset side, and then tighten the other adjusting screw on the offset side, bringing the bubble to the center. When the bubble stays in the center, keep the tightness of the three screws uniformly.

14.3 TILT-SENSOR

Inspection

Leveling the equipment on the collimator. Check the value of tilt-sensor. If the value is larger than 30" when the total station is precisely leveled. Please adjust the tilt-sensor (e-bubble)

Adjustment

Select Main Menu: **[Setting]\ [Adjustment]\ [E-bubble Adjust]**.

Focusing the same target by horizontal right and left, press **[Setting]** to confirm the adjustment.

Note: please adjust the plate vial before the tilt sensor.

14.4 RETICLE UNIT

Inspection

1. Sight object A after leveling the equipment, lock the horizontal and vertical tangent unit and make sure that target A is in the center of cross-hair.
2. Move object A to the edge of the field of view, point A' by rotating the vertical tangent screw.
3. Adjustment is not necessary if object A moves along the vertical line of the reticle and point A' still in the vertical line.

Otherwise, as picture shown, A' is deviate to the center of the vertical cross-hair, it is necessary to adjust.

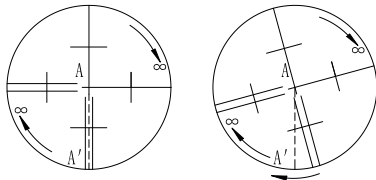

Adjustment

1. Remove the eyepiece cover to expose the four reticle adjusting screws, as picture shown.
2. Loosen the four reticle adjusting screws uniformly by the adjusting pin. Rotate the reticle around the sight line and align the vertical line of the reticle with point A'.
3. Tighten the adjusting screws slightly. Repeat the previous steps to see whether the position is correct.
4. Assemble the eyepiece cover back.

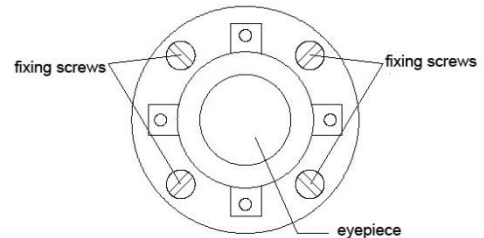

14.5 PERPENDICULARITY BETWEEN SIGHT OF VIEW & HORIZONTAL AXIS (2C)

Inspection

1. Set object A at a far distance at the same height as the instrument, leveling the instrument and turn on the power (eg. $HL=10^{\circ} 13'10''$).
2. Sight object A in horizontal left and read value of HA. (eg. $HR=190^{\circ} 13'40''$).
3. Loosen the vertical and horizontal tangent unit and rotate the telescope. Sight object A in horizontal right and read the HA.
4. $2C = HL - HR \pm 180^{\circ} = -30'' \geq \pm 20''$, overrange. So it is necessary to adjust 2C.

Adjustment

1. Use the horizontal tangent screw to adjust the reading of HA.
 $HR + C = 190^{\circ} 13'40'' - 15'' = 190^{\circ} 13'25''$
2. Take off the cover of the reticle between the eyepiece and focusing screw. Adjust the two adjusting screws, loosening one screw and tightening the other one. Move the reticle to sight object A exactly.
3. Repeat inspection and adjustment until $|2C| < 20''$. Then replace the cover of the reticle.

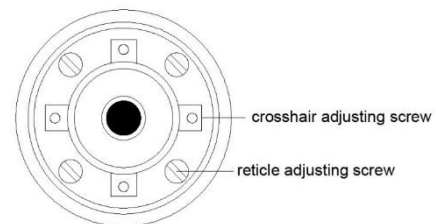

14.6 PERPENDICULARITY BETWEEN VERTICAL & HORIZONTAL AXIS

Inspection

1. Leveling the equipment at the collimator. Aim at the cross-hair in upper tube of collimator by HL.
2. Set the horizontal angle to 0.([Measure]\[0 Set/H Set]\[OK])
3. Rotate the telescope vertically to the lower tube. Rotate the horizontal tangent screw to the nearest scale, record the angle as A.
4. Repeat the steps by horizontal right. Read the nearest scale of the lower tube, record it as B.
5. The difference between A and B should be less than 0.6".

Adjustment, Method 1

1. Select Main Menu: [Setting] \ [Adjustment] \ [H-Axis Error]
2. Press [Input] to enter the difference between A and B. Press [OK].

Adjustment, Method 2

1. Leveling the equipment at collimator.
2. Aim at the lower tube of collimator by HL. Press [OK] for 10 times.
3. Aim at the lower tube of collimator by HR. Press [OK] for 10 times.

14.7 COMPENSATION OF VERTICAL INDEX DIFFERENCE

Inspection

1. After leveling the instrument, make the EDM parallel with the line connecting the center of the instrument to any one of the screws. Lock the horizontal clamp screw.
2. Switch on the equipment, zero the vertical index. Lock the vertical clamp screw and the instrument will display the vertical angle value.
3. Rotate the vertical tangent unit slowly in either direction about 10mm in circumference, and the over-range message appears. It means that the tilt of vertical axis is larger than $4'$, over the

range of compensation. When rotate the vertical tangent unit in opposite direction back to the original place, the instrument will show the vertical angle again, it means that the compensation of vertical index difference works well.

Adjustment

If the compensation function is not working, please send the instrument back to the authorized agency for maintenance.

14.8 VERTICAL 0 (I ANGLE)

The adjustment of vertical index difference (the so-called i-angle). This item must be adjusted after finishing the adjustment of tilt-sensor and cross-hair.

Inspection

1. After leveling the instrument, aim at any target A in HL. Record the value as L.
2. Rotate the EDM and aim at the target A in HR. Record the value as R.
3. If the vertical 0° in zenith, $I = (L + R - 360^\circ) / 2$. If the vertical 0 in horizon, $I = (L + R - 180^\circ) / 2$ or $(L + R - 540^\circ) / 2$.
5. If $|i| \geq 10''$, it need to reset the Vertical 0.

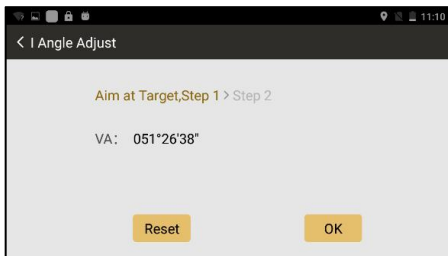

Adjustment

1. Aim at target A in same height with the instrument in HL.
 2. Aim at the same target A on HR.
 3. After setting the angle in both HL and HR, it will display the index difference, press [Reset] to confirm the adjustment.
 4. Repeat the inspection steps to check the Index Difference (i angle). If the difference still cannot meet the requirement, please check whether the steps you did are correct. Then reset again.
 5. If the Index Difference still fails to meet the requirement after repeated operation, the instrument should be returned to our authorize service center for inspection and repair.
- Note: The value of vertical angle is not adjusted and compensated, just for a reference in adjustment.

14.9 COMBINED ADJUSTMENT (I-ANGLE, 2C, E-BUBBLE)

Adjustment

- 1) Select Main Menu: **[Setting] \ [Adjustment] \ [Combine]**.
- 2) Aim at a target in Horizontal Left (F1), press **[OK]**.
- 3) Rotate the equipment to Horizontal Right (F2), aim at the same target and press **[OK]**
- 4) Check and tick the item to be adjusted.
- 5) Press **[Setting]** to confirm the adjustment.

14.10 INSTRUMENT CONSTANT K

The Instrument constant has been checked and adjusted in the factory, and $K=0$. It seldom changes and it is suggested to check once or twice in a year.

Inspection

1. Mount and level the instrument on Point A on flat ground. Use the vertical hair to mark Point B and Point C with the distance of 50m on the same line, aim the reflector accurately.
2. After setting temperature and pressure value, measure the horizontal distance of AB and AC accurately.
3. Setup the instrument on Point B and center it accurately. Measure the horizontal distance of BC accurately.
4. Then you can get the Instrument Constant:
 $K = AC - (AB + BC)$. The value of K should be close to 0. If $|K| > 5\text{mm}$, the instrument should be

strictly inspected on the base alignment, and be adjusted according to the inspection value.

Adjustment

Set the orientation through the vertical hair to make Point A,B, and C on the same line strictly. There must be a fixed and clear centering mark under the Point B.

The coincidence of the center of the prism and the center of the instrument is very essential to

the measuring accuracy. Therefore, it' s best to use a tripod or a common-used tribrach on the point B. If we replace it with a three-foot adapter and a tribrach, make sure that they are stable and fixed. It is possible to reduce the inconsistency if we just replace the upper part of the prism and the upper part of the instrument.

14.11 COINCIDENCE BETWEEN SIGHT OF VIEW AND EMITTING AXIS

Inspection

1. Set the reflector 50m away from the instrument. Aim at the center of prism precisely.
2. Activate the laser pointer. Check whether the center of reticle coincides to the laser pointer. If no, please adjust the emitting axis.

Adjustment

If there is a huge deviation between the sight of view and emitting axis, please send the instrument to authorized service center for maintenance.

APPENDIX A. MENU TREE

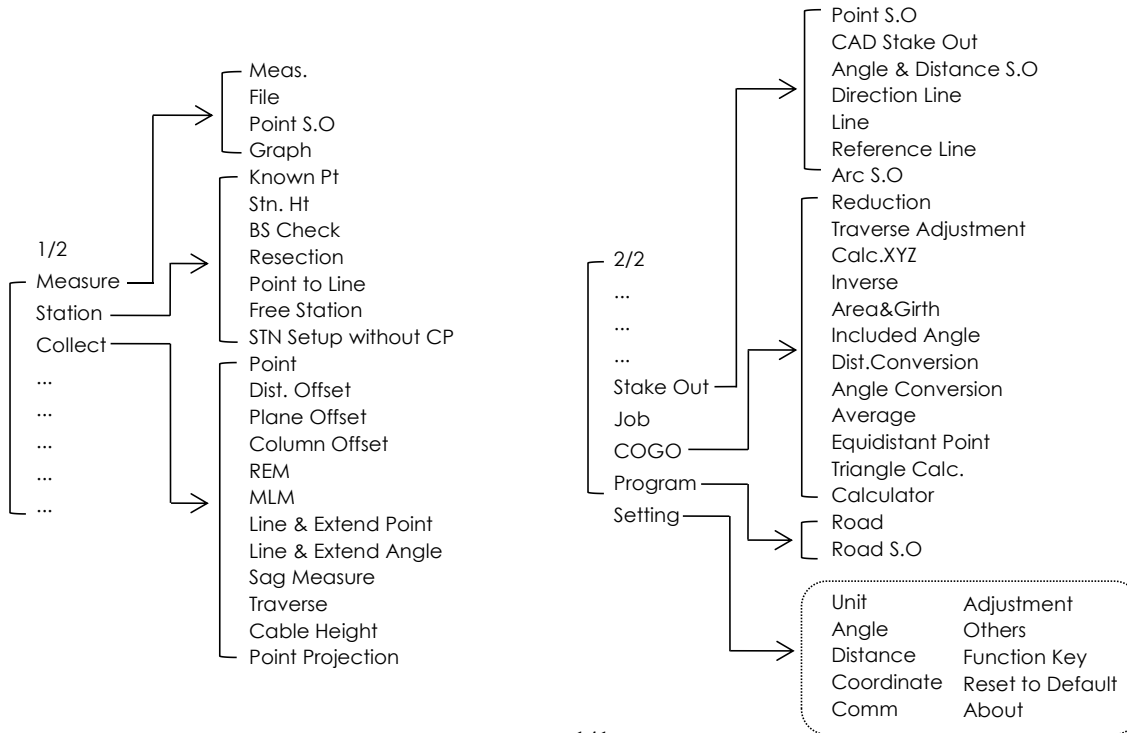

APPENDIX B. DATA FORMAT

1. RAW DATA

LINE	EXPLANATION	
JOB	Job name, descriptions	
DATE	Date and time	
NAME	Operator's name	
INST	Serial number	
ORDER	Coordinate order	
VAMODE	Z(V0), H(H0), V(± 90)	
L/R	Horizontal left or right	
UNITS	Distance unit, angle unit, temperature unit, pressure unit.	
SCALE	Grid factor, scale factor, elevation	
ATMOS	Temperature, Pressure	
ST	Station Point	Point ID, Code, N, E, Z (or E,N,Z), station height, date&time
BKB	Backsight Point	Backsight ID, code, reflector height, azimuth($123^{\circ} 12'45''=123.1245$), date&time
MP	Measured Point	Point ID, code, N, E, Z (or E,N,Z), date and time
UP	Imported Point	Point ID, code, N, E, Z (or E,N,Z), date and time

GPS	GPS Point	Point ID, code, N, E, Z (or E,N,Z), date and time
CC	Calculated Point	Point ID, code, N, E, Z (or E,N,Z), date and time
SS	Side Shot	Point ID, code, reflector height, horizontal angle, vertical angle, SD, HD, VD, N, E, Z (or E,N,Z), date and time
ANG	Angle	Point ID, code, reflector height, horizontal angle, vertical angle, SD, HD, VD, date and time
SO	Stake Out Point	Point ID, code, N, E, Z (or E,N,Z), reflector height, horizontal angle, vertical angle, SD, HD, VD, dx,dy,dz, date and time

2. COORDINATES DATA

LINE	EXPLANATION
JOB	Job name, descriptions
DATE	Date and time
NAME	Operator's name
INST	Serial number
UNITS	M
ORDER	Coordinate order (which can be changed)
Details	Point ID, code, N, E, Z

3. CODE LIST

(Header)

(Codes)

(Codes)

Q-code	Code*	Color	Name
K01	230421	1	
K02	230421	2	

*Color refers to the color marks in Southmap or CAD. Marked from 1 to 9.

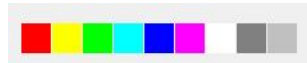

APPENDIX C. TRAVERSE LEVEL

Level	Traverse Length (km)	Side Length (km)	Mid Error (Ang.) (")	Mid Error (Dist) (mm)	Relative Measuring Error (Dist)	Measure Rounds		Azimuth Closing Error (")	Relative Closing Error
						1"	2"		
3 rd level	14	3	1.8	20	1/150000	6	10	$3.6\sqrt{n}$	$\leq 1/55000$
4 th level	9	1.5	2.5	18	1/80000	4	6	$5\sqrt{n}$	$\leq 1/35000$
1 st Class	4	0.5	5	15	1/30000	/	2	$10\sqrt{n}$	$\leq 1/15000$
2 nd Class	2.4	0.25	8	15	1/14000		1	$16\sqrt{n}$	$\leq 1/10000$
3 rd Class	1.2	0.1	12	15	1/7000		1	$24\sqrt{n}$	$\leq 1/5000$